

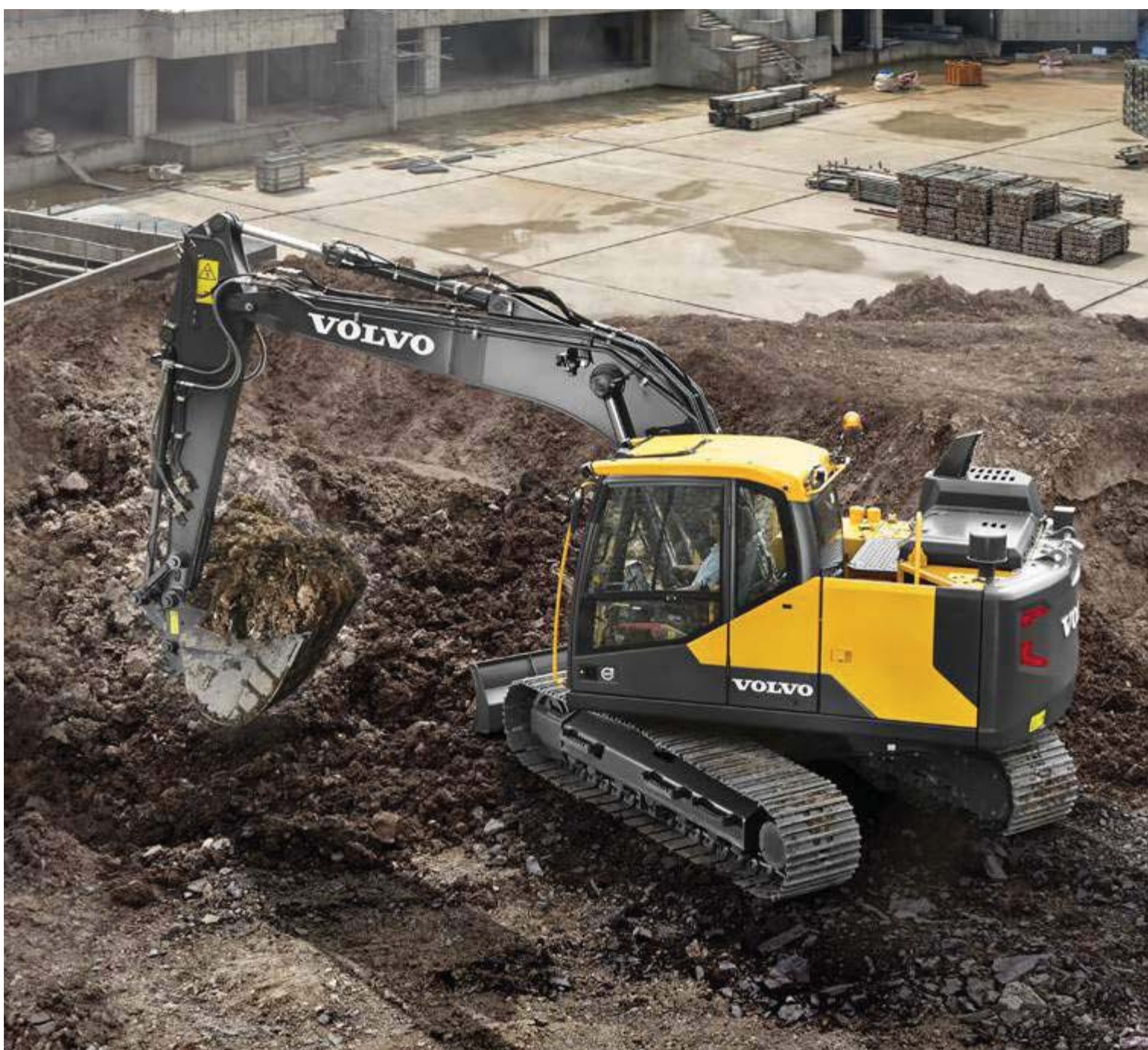

Volvo Construction Equipment

EC140E

VOLVO EXCAVATORS 14.4 - 16.1 t / 31,220 - 35,500 lb 121 hp



A passion for performance.

At Volvo Construction Equipment, we're not just coming along for the ride. Developing products and services that raise productivity – we are confident we can lower costs and increase profits for customers around the globe. Part of the Volvo Group, we are passionate about innovative solutions to help you work smarter – not harder.

Helping you to do more

Doing more with less is a trademark of Volvo Construction Equipment. High productivity has long been married to low energy consumption, ease of use and durability. When it comes to lowering life-cycle costs, Volvo is in a class of its own.

Designed to fit your needs

There is a lot riding on creating solutions that are suited to the particular needs of different industry applications. Innovation often involves high technology – but it doesn't always have to. Some of our best ideas have been simple, based on a clear and deep understanding of our customers' working lives.



You learn a lot in 180 years

Over the years, Volvo has advanced solutions that have revolutionized the use of construction equipment. No other name speaks Safety louder than Volvo. Protecting operators, those around them and minimizing our environmental impact are traditional values that continue to shape our product design philosophy.

We're on your side

We back the Volvo brand with the best people. Volvo is truly a global enterprise, one that is on standby to support customers quickly and efficiently – wherever they are.

We have a passion for performance.

A strong, dedicated, capable dealer network.

Our dealers are strategically located throughout North America to provide the equipment you need and the parts and service support you demand for a productive and profitable operation.

The strength of our dealer network is enhanced with extensive individualized product support training at our best-in-class Customer Center in Shippensburg and through hands-on training. Using a great Product Demonstration Center featuring a dedicated area for most common applications, visitors operate equipment from our entire product line under a variety of simulated working conditions. This facility is in year-round use by our dealers and customers.

Building the best starts right here.

The products designed and manufactured by Volvo Construction Equipment have their beginnings at the most advanced Research & Design centers in the industry. Volvo CE machines are designed in 11 R&D centers and produced in 15 manufacturing facilities across the world.

The major R&D center and manufacturing plant in the Americas is located in Shippensburg, Pennsylvania. This facility has been in operation for over 30 years and – with its recently added 200,000 sq. ft. expansion – now covers 570,000 sq. ft. on an 80 acre campus. Dedicated work teams and highly advanced technologies and techniques using the Volvo Production System ensure continuous quality improvements, labor savings and cost control to reach the high quality that our customers have come to expect from Volvo.





Volvo Trucks



Renault Trucks



Mack Trucks



UD Trucks



Volvo Buses



Volvo Construction Equipment



Volvo Penta



Volvo Financial Services

Efficient Effective Performance.

All the EC140E features have been designed to work in harmony to deliver every function with superior efficiency. The machine not only produces maximum uptime it also incorporates the latest fuel efficiency technology, to reduce emissions and consumption, while increasing productivity.

Volvo engine

Featuring proven advanced technology, and built on decades of experience, Volvo's robust D4 Tier 4 Final engine boasts more power - while reducing both fuel consumption and emissions to deliver superior quality, reliability and durability.



Increased power

The increased engine power combined with the increased pump flow creates a highly responsive combined operation and travel. These improvements produce faster cycle times and lower fuel consumption which leads to higher productivity.

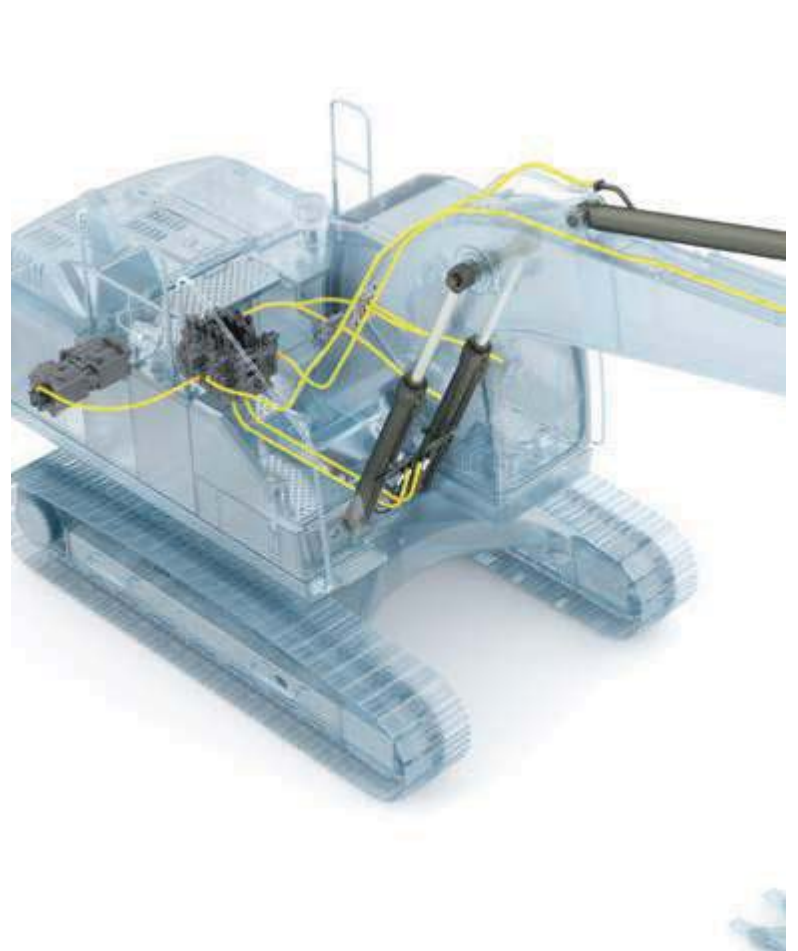

Boom float function

With the boom float function, the pump flow for boom lowering can be transferred to other functions, reducing the cycle time. Boom float can also make grading much easier.

Auto engine shutdown

To reduce fuel consumption, the engine will automatically switch off when the machine is inactive for a pre-set amount of time (five minutes is the default setting).

Main Control Valve and Software

This valve is compatible with software in the machine - building on the already superior controllability by providing a smooth and easy operation. It is also compatible with Volvo's ECO mode - this provides electronic pump control to enhance fuel efficiency.



Optimized hydraulics system

The hydraulics system, combined with the fully electronic control system and advanced ECO mode, has been optimized to work in parallel with D4 Tier 4 Final engine to match the engine power, reduce power loss and improve controllability and response time.



Human Machine Interface (HMI)

All machine interfaces – including joysticks, keypad, panel and larger LCD monitor – are ergonomically designed for optimum control and efficiency, resulting in increased productivity and operator comfort. The number of switches have been simplified and climate control integrated into the keypad for easy adjustments.

Easy to see why it's first choice.

Building on the already strong reputation for operator space and comfort, Volvo has taken the E-Series excavator cabs to a whole new level. By putting operator comfort first, Volvo has developed a cab for the EC140E which has everything at the operator's fingertips. Not only will operators be more comfortable – they will be more productive.

Side view camera

As well as the rear view camera, there is now a side view camera option to cover the visual blind spot. Both views are displayed on the color monitor, creating a safer working environment, protecting the operator and personnel on the ground.



Short-cut key

For added convenience, functions such as windshield wipers, cameras, auto-mute function can all be assigned a short-cut button on the joystick. This allows the operator to select a function during the application without disruption.



Bluetooth®

To aid operator convenience and support better productivity, you can now connect a Bluetooth device to the machine enabling the hands free function.



Climate control system

With more than 98% efficiency, Volvo's air filtration system provides the cleanest operator environment in the industry – even in dusty conditions. The high-capacity heating and ventilation system improves comfort, enhancing productivity.

Increasing your Expectations.

Volvo stands for quality and the EC140E is a symbol of this. It is a machine full of state of the art features, but the number one priority of every feature is durability. Your working conditions are some of the most demanding, and the EC140E delivers quality which you can be rely on.

ROPS

Volvo cabs are ROPS certified according to the rigorous ISO standards. Their reinforced steel structures ensure the operator is protected in the unlikely event of the machine rolling over..



Boom and Arm

The robust design includes internal plates positioned to support pressure points during the range of applications. This helps disperse the stress from high-pressure areas of the boom and arm, to ensure maximum productivity time after time, during the most demanding applications.



Lower frame

The intelligently designed X-shape lower frame enables even weight distribution increasing stability and durability - preventing damage from rock and debris.



Undercarriage

The idlers, track links, upper and bottom rollers are built to withstand all elements and terrain, to create improved long-lasting durability and support maximum uptime.



Built to last

Working in tough conditions means every component matters - this is why Volvo pays extra attention to each detail during the manufacturing process. Silicone caulking is used to prevent rust, waterproof harnesses and connections are installed - as well as heavy-duty door hinges and bolted-on protection for the work lights.



Ultimate tool carrier

The Volvo excavator can be outfitted with a wide variety of auxiliary circuits from the factory, from breaker and shear piping (X1) to rotator piping (X3). State of the art hydraulics provide the correct flow and pressure for special attachments such as mowers and grinders, shears, crushers and tilt rotators among other attachments. You can choose between the one or two pump flow to maximize profits and productivity.

The Pick of the Bunch.

No customer has one job, so a machine should mirror these requirements. Volvo has listened to customer needs and built a machine in the EC140E that is not only capable of doing a variety of applications but can do them all at an unrivaled consistent quality – easily switching between attachments to maximize uptime and productivity.

Attachment Management System

The password protected management system allows storage for up to 20 different attachments. It pre-sets and permits hydraulic flow and pressure to be adjusted within the cab, which ensures the use of various attachments for increased versatility.

Extra piping

An additional piping solution is available on the breaker and shear piping (X1), accommodating the use of tilt/rotator attachments.



Electrical pedal

The electric pedal offers precise control to allow the operator to use a wider variety of attachments.

Response mode

The attachment response sensitivity can be adjusted using the keypad. This allows the operator to tailor machine response for maximum impact in different environments.

Routine check-ups.

Proactive maintenance is crucial to prolong machine life – this is why making inspections safe and easy is a priority. Volvo has grouped access points together and made them safer to reach to ensure regular checks to maximise machine uptime while reducing the chances of any surprises.

Grouped filters

Filters are well grouped and easily accessible from the ground level. This facilitates the speed and ease of servicing.



Single layer cooling system

The radiator, charged air cooler and hydraulic oil cooler are situated side-by-side on a single layer, to maximize efficiency, reduce blockages and aid cleaning. The system is easily accessed from ground level by simply opening the side door.



Service interval alerts

Real-time service alerts are displayed on the color monitor to enable diagnostic checks. Separate service intervals include – the engine oil filter, fuel filter, water separator, hydraulic oil and hydraulic oil filter. This ensures peace of mind and maximum uptime.



Anti-slip steel plates

Well-positioned punched anti-slip plates provide superior grip and durability. The design facilitates easy cleaning while promoting safety.



Service access

Easy access for maintenance means regular checks are completed faster – increasing uptime and driving down total cost of ownership. The E-series features safe access guardrails to assist in checking the hydraulic tank, fuel tank and Diesel Exhaust Fluid (DEF). This is in addition to the easily accessible side entry, through a wide compartment door.



Matched attachments

Volvo's durable attachments have been purpose-built to work in perfect harmony with Volvo machines, forming one solid, reliable unit. With functions and properties ideally matched, Volvo attachments are an integrated part of the excavator for which they're intended.

Mix and match for a superior fit.

Maximize your productivity and profitability with Volvo's EC140E crawler excavator and a range of durable attachments. Increase your versatility, access more applications and perform a variety of tasks – all while experiencing faster cycle times and excellent control.

Buckets – GP/HD/XD

Volvo's buckets are the perfect tool for digging and re-handling in all conditions from soft, medium and hard materials. Heavy-duty buckets are intended for productive digging in compact materials. All provide maximum productivity and long life and feature the Volvo Tooth System.



Breakers

The HB-Series of hydraulic breakers are optimized to the specific weights of Volvo machines and tailored to Volvo quick couplers for swift, safe and simple attachment changes. They are available with a full assortment of tools.



S-type Coupler

The Volvo S-type quick coupler is designed to work with Volvo attachments - delivering ultimate compatibility and unrivalled performance.

Genuine Volvo wear parts

Volvo offers a selection of economic, replaceable wear parts including high quality teeth, segments, side cutters, adapters and shrouds to protect the bucket and ensure long life.



Universal Quick Coupler

The Volvo universal quick coupler offer maximum versatility. It picks up a variety of attachments from various manufacturers and meets new safety regulations.

Improved total cost of ownership.

Boom and arm

To achieve the best performance, select the most suitable boom and arm configuration combination for your requirements.



Ultimate tool carrier

Designed to not only be compatible with a range of attachments, but also to enhance their performance by easily and quickly switching to accommodate any needs.



Optimized hydraulics

Designed to perfectly match the engine power, reduce power loss, and improve controllability and response time.

Diesel Exhaust Fluid (DEF)

Volvo offers a total DEF solution that is quality assured, cost efficient and easily accessible. Contact your Volvo dealer for more information.

Boom float

The pump flow for boom lowering can be transferred to functions, reducing the cycle time. Also, the grading operation can be made easier.

Attachment management system

The password protected management system allows storage for up to 20 different attachments. It pre-sets and permits hydraulic flow and pressure to be adjusted within the cab.



Side view camera

Covers the visual blind spot at the side of machine. View is displayed on the color monitor, creating a safer working environment, protecting the operator and personnel on the ground.

Short cut key function

For ease of use, functions such as windshield wipers, cameras, auto-mute function can all be assigned a short-cut button on the joystick



HMI

All machine interfaces are ergonomically positioned and designed for optimum control and efficiency.

Bluetooth®

Bluetooth and hands-free functions have been added, allowing the operator to connect to wireless functions for increased comfort and safety.



Service access

The E-series features a new convenient and safe access - such as guardrails - to check the hydraulic tank, fuel tank and Diesel Exhaust Fluid. This is in addition to the easily accessible side entry, through a wide compartment door.

Volvo engine

Volvo's D4 Tier 4 Final IV engine boasts more power while reducing both fuel consumption and emissions; delivering superior quality, reliability and durability.

Grouped filters

Filters are well grouped and easily accessible from the ground level. This facilitates the speed and ease of servicing.



Built to last

Volvo pays attention to detail. Silicone caulking is used to prevent rust, waterproof harnesses and connections have been installed - as well as heavy-duty door hinges and bolted-on protection for the framework lights.



Adding value to your business.

Being a Volvo customer means having a complete set of services at your fingertips. Volvo can offer you a long-term partnership, protect your revenue and provide a full range of customer solutions using high quality parts, delivered by passionate people. Volvo is committed to the positive return of your investment.



Complete Solutions

Volvo has the right solution for you. So why not let us provide all your needs throughout the whole life cycle of your machine? By listening to your requirements, we can reduce your total cost of ownership and increase your revenue.



Genuine Volvo Parts

Our attention to detail is what makes us stand out. This proven concept acts as a solid investment in your machine's future. Parts are extensively tested and approved because every part is vital for uptime and performance. Only by using Genuine Volvo Parts, can you be sure that your machine retains the renowned Volvo quality.



Service Network

In order to respond to your needs faster, a Volvo expert is on their way to your job site from one of our Volvo facilities. With our extensive infrastructure of technicians, workshops and dealers, Volvo has a comprehensive network to fully support you using local knowledge and global experience.



SERVICE PLAN

	DAY01	DAY02	DAY03	DAY04	DAY05	DAY06	DAY07
Task 1							✓
Task 2		✓		✓	✓		
Task 3			✓			✓	✓
Task 4	✓						
Task 5			✓				
Task 6							
Task 7							



Customer Support Agreements

The range of Customer Support Agreements offer preventive maintenance, total repairs and a number of uptime services. Volvo uses the latest technology to monitor machine operation and status, giving you advice to increase your profitability. By having a Customer Support Agreement you are in control of your service costs.

Volvo EC140E in detail.

Engine

The latest generation of Volvo Tier 4 Final diesel engines fully meets the demands of the latest, emissions regulations. Featuring Volvo Advanced Combustion Technology (V-ACT), it is designed to deliver superior performance and fuel efficiency. The engine uses precise, high pressure fuel injectors, turbo charger and air-to-air intercooler, and electronic engine controls to optimize machine performance.

Automatic Idling System reduces engine speed to idle when the levers and pedals are not activated resulting in less fuel consumption and low cab noise levels.

Engine	Volvo		D4J	
Max power at	r/min		2,000	
Net, ISO 9249/SAE J1349	kW	hp	89	119
Gross, ISO 14396/SAE J1995	kW	hp	90	121
Max power	Nm	lbf ft	566	417
at engine speed	r/min		1,500	
No. of cylinders			4	
Displacement	l	in ³	4.04	247
Bore	mm	in	101	3.98
Stroke	mm	in	126	4.96

Electrical system

Well protected high-capacity electrical system. Waterproof double-lock harness plugs are used to ensure corrosion-free connections. The main relays and solenoid valves are shielded to prevent damage. The master switch is standard.

Contronics provides advanced monitoring of machine functions and important diagnostic information.

Voltage	V	24
Batteries	V	2 x 12
Battery capacity	Ah	100
Alternator	V / Ah	28/80

Service refill capacities

Fuel tank	l	gal	250	66
Hydraulic system, total	l	gal	230	61
Hydraulic tank	l	gal	85	22
DEF tank	l	gal	20	5
Engine oil	l	gal	16	4
Engine coolant	l	gal	28	7
Swing reduction unit	l	gal	3.9	1
Travel reduction unit	l	gal	2 x 2.2	2 x 1

Swing system

The swing system uses an axial piston motors, driving a planetary gearbox for maximum torque. An automatic holding brake and anti-rebound valve are standard.

Max. slew speed	r/min		12.5	
Max. slew torque	kNm	lbf ft	38.8	28,620

Drive

Each track is powered by an automatic two-speed shift travel motor. The track brakes are multi-disc, spring-applied and hydraulic released. The travel motor, brake and planetary gears are well protected within the track frame.

Max. drawbar pull	kN	lbf	119	26,680
Max. travel speed	km/h	mph	3.1/5.5	1.9/3.4
Gradeability			° 35	

Undercarriage

Robust X-shaped frame with greased and sealed track chains as standard.

Track shoe	2 x 46			
Link pitch	mm	in	171	6.8
			500	20
Shoe width, triple grouser	mm	in	600	24
			700	28
			750	30
Shoe width, triple grouser (HD)	mm	in	600	24
Shoe width, rubber grouser	mm	in	500	20
Bottom rollers	2 x 7			
Top rollers	2 x 1			

Hydraulic system

The hydraulic system, combined with the fully electronic control system and advanced ECO mode, has been optimized to work in harmony with engine to match the engine power, reduce power loss and improve controllability and response time.

The following important functions are included in the system:

Summation system: Combines the flow of both hydraulic pumps to ensure quick cycle times and high productivity.

Arm priority: Gives priority to the arm operation for faster cycle times in leveling and for increased bucket filling when digging.

Swing priority: Gives priority to swing functions for faster simultaneous operations.

Regeneration system: Prevents cavitation and provides flow to other movements during simultaneous operations for maximum productivity.

Power boost: All digging and lifting forces are increased.

Holding valves: Boom and arm holding valves prevent the digging equipment from creeping.

Main pump

Type	2 x variable displacement axial piston pumps			
------	--	--	--	--

Maximum flow	l/min	gpm	2 x 124	2 x 33
--------------	-------	-----	---------	--------

Pilot pump,

Type	Gear pump			
------	-----------	--	--	--

Maximum flow	l/min	gpm	1 x 20	1 x 5
--------------	-------	-----	--------	-------

Relief valve setting:

Implement	MPa	psi	32.4/34.3	4,690/4,980
-----------	-----	-----	-----------	-------------

Travel circuit	MPa	psi	34.3	4,980
----------------	-----	-----	------	-------

Slew circuit	MPa	psi	24.5	3,560
--------------	-----	-----	------	-------

Pilot circuit	MPa	psi	3.9	570
---------------	-----	-----	-----	-----

Hydraulic motors

Travel: Variable displacement axial piston motor with mechanical brake

Slew: Fixed displacement axial piston motor with mechanical brake

Hydraulic cylinders

Mono boom				2
-----------	--	--	--	---

Bore x Stroke	ø x mm	ø x in	105 x 980	4.1 x 38.6
---------------	--------	--------	-----------	------------

2 piece boom				1
--------------	--	--	--	---

Bore x Stroke	ø x mm	ø x in	160 x 765	6.3 x 30.1
---------------	--------	--------	-----------	------------

Arm				1
-----	--	--	--	---

Bore x Stroke	ø x mm	ø x in	120 x 1 045	4.7 x 41.1
---------------	--------	--------	-------------	------------

Bucket				1
--------	--	--	--	---

Bore x Stroke	ø x mm	ø x in	100 x 865	3.9 x 34.1
---------------	--------	--------	-----------	------------

Dozer blade				2
-------------	--	--	--	---

Bore x Stroke	ø x mm	ø x in	130 x 270	5.1 x 10.6
---------------	--------	--------	-----------	------------

Cab

The operator's cab has easy access via a wide door opening. The cab is supported on hydraulic dampening mounts to reduce shock and vibration levels. These along with a sound absorbing lining provide low noise levels. The cab has excellent all-round visibility. The front windshield can easily slide up into the ceiling, and the lower front glass can be removed and stored in the side door.

Integrated air-conditioning and heating system: The pressurized and filtered cab air is supplied by an automatically-controlled fan. The air is distributed throughout the cab from 14 vents.

Ergonomic operator's seat: The adjustable seat and joystick console move independently to accommodate the operator.

The seat has nine different adjustments plus a seat belt for the operator's comfort and safety.

Sound Level

Sound level in cab according to ISO 6396

LpA (standard)	dB(A)	69
----------------	-------	----

LpA (tropical)	dB(A)	70
----------------	-------	----

External sound level according to ISO 6395, EU Noise Directive (2000/14/EC)

LwA (standard)	dB(A)	100
----------------	-------	-----

LwA (tropical)	dB(A)	101
----------------	-------	-----

Specifications.

DIMENSIONS

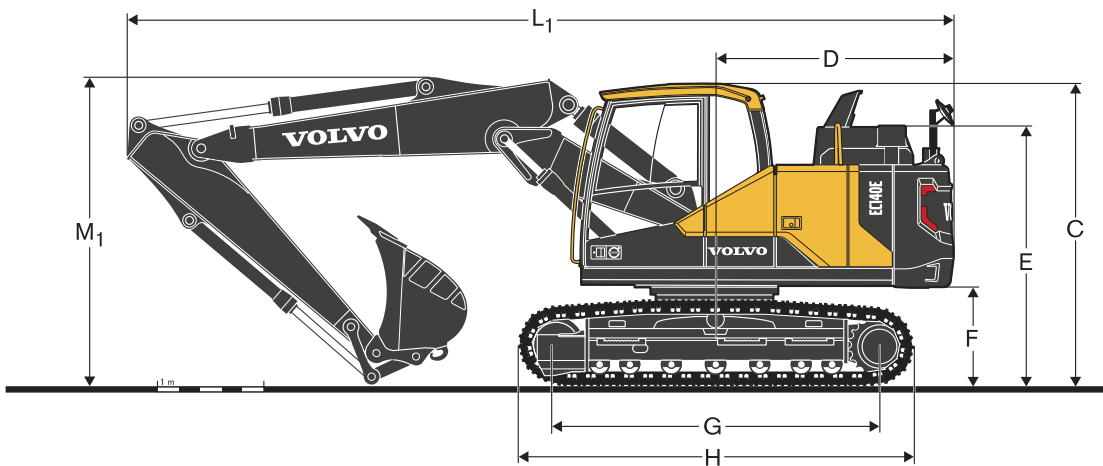
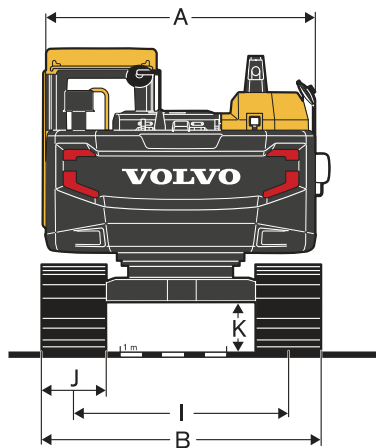
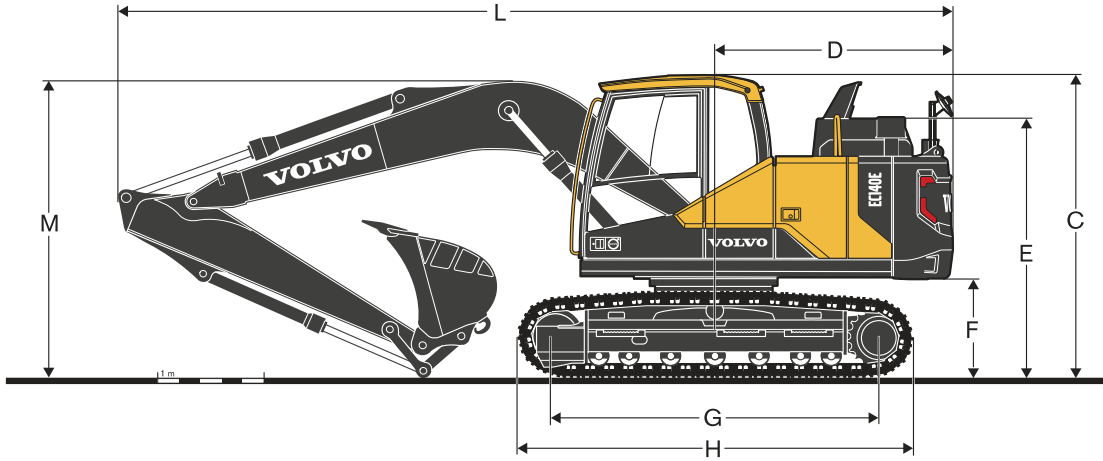

DIMENSIONS

Description	Unit		EC140EL					
	m, ft in		4.6, 15' 1"					
Boom (mono & 2-piece)	m	ft in	2.1	6' 11"	2.5	8' 2"	3.0	9' 10"
Arm	m	ft in						
A Overall width of upper structure	mm	ft in	2 490	8' 2"	2 490	8' 2"	2 490	8' 2"
B Overall width	mm	ft in	2 590	8' 6"	2 590	8' 6"	2 590	8' 6"
C Overall height of cab	mm	ft in	2 800	9' 2"	2 800	9' 2"	2 800	9' 2"
D Tail swing radius	mm	ft in	2 200	7' 3"	2 200	7' 3"	2 200	7' 3"
E Overall height of engine hood	mm	ft in	2 400	7' 10"	2 400	7' 10"	2 400	7' 10"
F Counterweight clearance*	mm	ft in	920	3' 0"	920	3' 0"	920	3' 0"
G Tumbler length	mm	ft in	3 040	10' 0"	3 040	10' 0"	3 040	10' 0"
H Track length	mm	ft in	3 760	12' 4"	3 760	12' 4"	3 760	12' 4"
I Track gauge	mm	ft in	1 990	6' 6"	1 990	6' 6"	1 990	6' 6"
J Shoe width	mm	ft in	600	2' 0"	600	2' 0"	600	2' 0"
K Min. ground clearance*	mm	ft in	436	1' 5"	436	1' 5"	436	1' 5"
L Overall length	mm	ft in	7 720	25' 4"	7 720	25' 4"	7 650	25' 1"
L ₁ Overall length	mm	ft in	7 700	25' 3"	7 660	25' 2"	7 560	24' 10"
M Overall height of boom	mm	ft in	2 710	8' 11"	2 830	9' 3"	3 210	10' 6"
M ₁ Overall height of boom	mm	ft in	2 720	8' 11"	2 860	9' 5"	3 310	10' 10"

* Without shoe grouser

₁ 2-piece boom

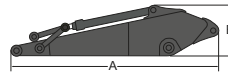
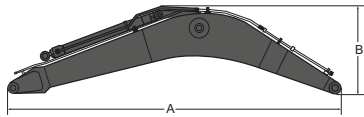

Description	Unit		mono		2-piece		Description	Unit		EC140EL					
	m	ft in	4.6	15' 1"	4.6	15' 1"		m	ft in	2.1	6' 11"	2.5	8' 2"	3.0	9' 10"
Boom	m	ft in					Arm	m	ft in						
A Length	mm	ft in	4 770	15' 8"	4 765	15' 8"	A Length	mm	ft in	2 800	9' 2"	3 200	10' 6"	2 700	8' 10"
B Height	mm	ft in	1 370	4' 6"	1 225	4' 0"	B Height	mm	ft in	710	2' 4"	710	2' 4"	710	2' 7"
Width	mm	ft in	545	1' 9"	545	1' 9"	Width	mm	ft in	300	1' 0"	300	1' 0"	300	1' 0"
Weight	kg	lb	1 100	2,430	1 900	4,190	Weight	kg	lb	555	1,220	625	1,380	685	1,510

* Includes cylinder, piping and pin, excludes boom cylinder pin

* Includes cylinder, linkage and pin

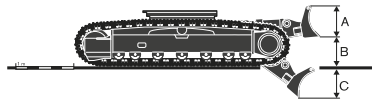

Front dozer blade		Unit			
A	Height	mm	ft in	580	1' 11"
	Width	mm	ft in	2 590	8' 6"
	Weight	kg	lb	458	1,260
B	Lift height	mm	ft in	480	1' 7"
C	Digging depth	mm	ft in	600	2' 0"

Specifications.

WORKING RANGES

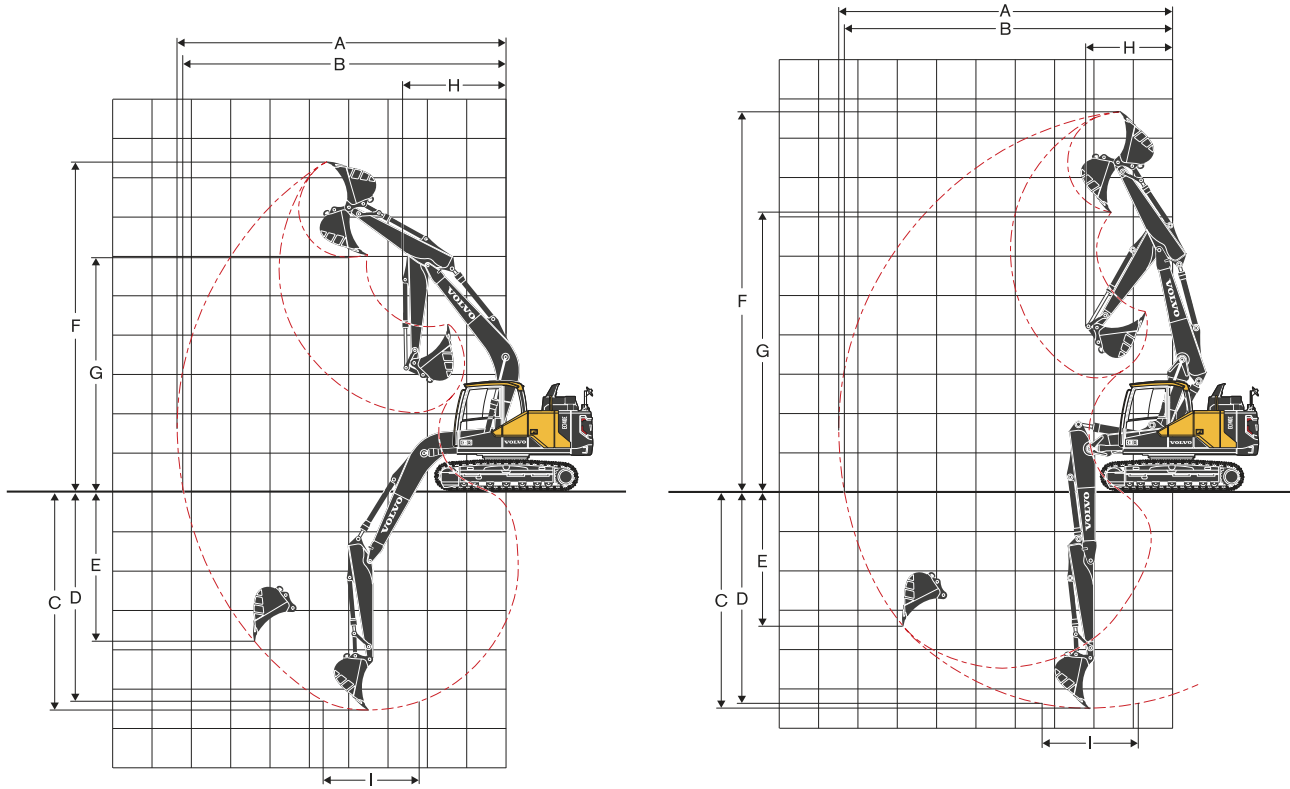

WORKING RANGES

Description	Unit	EC140EL											
		4.6, 15' 1" mono						4.6, 15'1" 2-piece					
Boom	m, ft in	2.1	6' 11"	2.5	8' 2"	3.0	9' 10"	2.1	6' 11"	2.5	8' 2"	3.0	9' 10"
A Max. digging reach	mm ft in	7 980	26' 2"	8 360	27' 5"	8 850	29' 0"	8 080	26' 6"	8 460	27' 9"	8 960	29' 5"
B Max. digging reach on ground	mm ft in	7 840	25' 9"	8 220	27' 0"	8 720	28' 7"	7 930	26' 0"	8 320	27' 4"	8 830	29' 0"
C Max. digging depth	mm ft in	5 160	16' 11"	5 560	18' 3"	6 060	19' 11"	5 080	16' 8"	5 480	18' 0"	5 980	19' 7"
D Max. digging depth (2.44 m / 8' level)	mm ft in	4 900	16' 1"	5 340	17' 6"	5 880	19' 3"	4 960	16' 3"	5 360	17' 7"	5 870	19' 3"
E Max. vertical wall digging depth	mm ft in	3 970	13' 0"	4 330	14' 2"	4 870	16' 0"	3 970	13' 0"	4 340	14' 3"	4 830	15' 10"
F Max. cutting height	mm ft in	8 120	26' 8"	8 360	27' 5"	8 710	28' 7"	9 270	30' 5"	9 630	31' 7"	10 110	33' 2"
G Max. dumping height	mm ft in	5 720	18' 9"	5 950	19' 6"	6 290	20' 8"	6 730	22' 1"	7 100	23' 4"	7 570	24' 10"
H Min. front swing radius	mm ft in	2 570	8' 5"	2 630	8' 8"	2 740	9' 0"	1 740	5' 9"	1 990	6' 6"	2 410	7' 11"

DIGGING FORCES WITH DIRECT FIT BUCKET

Bucket radius		mm	ft in	1 274	4' 2"	1 274	4' 2"	1 274	4' 2"	1 274	4' 2"	1 274	4' 2"	1 274	4' 2"
Breakout force - bucket	Normal	SAE J1179	kN lbf	80.5	18,100	80.5	18,100	80.5	18,100	80.5	18,100	80.5	18,100	80.5	18,100
	Power boost	SAE J1179	kN lbf	85.4	19,200	85.4	19,200	85.4	19,200	85.4	19,200	85.4	19,200	85.4	19,200
	Normal	ISO 6015	kN lbf	91.1	20,480	91.1	20,480	91.1	20,480	91.1	20,480	91.1	20,480	91.1	20,480
	Power boost	ISO 6015	kN lbf	96.6	21,720	96.6	21,720	96.6	21,720	96.6	21,720	96.6	21,720	96.6	21,720
Tearout force - dipper arm	Normal	SAE J1179	kN lbf	69.6	15,640	62.1	13,960	55.2	12,420	69.6	15,640	62.1	13,960	55.2	12,420
	Power boost	SAE J1179	kN lbf	73.8	16,590	65.9	14,800	58.6	13,170	73.8	16,590	65.9	14,800	58.6	13,170
	Normal	ISO 6015	kN lbf	71.5	16,070	63.5	14,280	56.3	12,660	71.5	16,070	63.5	14,280	56.3	12,660
Power boost	ISO 6015	kN lbf	75.8	17,040	67.4	15,150	59.7	13,430	75.8	17,040	67.4	15,150	59.7	13,430	
Rotation angle, bucket		°		175	175	175	175	175	175	175	175	175	175	175	175

MACHINE WEIGHTS AND GROUND PRESSURE

EC140EL		4.6 m / 15' 1" boom, 2.5 m / 8' 2" arm, 410 kg / 900 lb - 540 l / 143 gal bucket, 2 450 kg / 5,400 lb counterweight						4.6 m / 15' 1" 2-piece boom						
Description	Shoe width		Operating weight		Ground pressure		Overall width		Operating weight		Ground pressure		Overall width	
	mm	in	kg	lb	kPa	psi	mm	in	kg	lb	kPa	psi	mm	in
Without dozer blade														
Triple grouser	500	20	14 160	31,220	42.2	6.1	2 490	8' 2"	14 580	32,150	43.1	6.3	2 490	8' 2"
	600	24	14 360	31,660	35.3	5.1	2 590	8' 6"	14 780	32,590	36.3	5.3	2 590	8' 6"
	700	28	14 560	32,100	31.4	4.6	2 690	8' 10"	14 980	33,030	31.4	4.6	2 690	8' 10"
	750	30	14 740	32,500	29.4	4.3	2 740	9' 0"	15 160	33,430	30.4	4.4	2 740	9' 0"
Triple grouser (HD)	600	24	14 430	31,820	35.3	5.1	2 590	8' 6"	14 850	32,740	37.3	5.4	2 590	8' 6"
Rubber grouser	500	20	14 200	31,310	42.2	6.1	2 490	8' 2"	14 620	32,240	43.1	6.3	2 490	8' 2"
With dozer blade														
Triple grouser	500	20	15 100	33,300	45.1	6.5	2 490	8' 2"	15 520	34,220	46.1	6.7	2 490	8' 2"
	600	24	15 300	33,740	38.2	5.5	2 590	8' 6"	15 720	34,660	39.2	5.7	2 590	8' 6"
	700	28	15 500	34,180	33.3	4.8	2 690	8' 10"	15 920	35,100	34.3	5.0	2 690	8' 10"
	750	30	15 680	34,570	31.4	4.6	2 740	9' 0"	16 100	35,500	32.4	4.7	2 740	9' 0"
Triple grouser (HD)	600	24	15 370	33,890	38.2	5.5	2 590	8' 6"	15 790	34,820	39.2	5.7	2 590	8' 6"
Rubber grouser	500	20	15 140	33,380	45.1	6.5	2 490	8' 2"	15 560	34,310	46.1	6.7	2 490	8' 2"

BUCKET SELECTION GUIDE

Bucket type		Capacity		Cutting width		Weight		Teeth	EC140EL						
									600 mm / 20' shoe, 2 100 kg / 4,630 lb counterweight			600 mm / 20' shoe, 2 450 kg / 5,400 lb counterweight			
				4.6 m / 15' 1" boom						2.1 m / 6' 11"	2.5 m / 8' 2"	3.0 m / 9' 10"	2.1 m / 6' 11"	2.5 m / 8' 2"	3.0 m / 9' 10"
		m ³	yd ³	mm	in	kg	lb	EA	arm	arm	arm	arm	arm	arm	
Direct fit Buckets	General purpose	0.66	0.86	1 050	41.34	480	1,059	4	C	C	C	C	C	C	
		0.77	1.01	1 200	47.24	541	1,193	5	C	C	B	C	C	C	
		0.25	0.33	450	17.72	330	729	3	C	C	C	C	C	C	
		0.33	0.43	600	23.62	361	797	3	C	C	C	C	C	C	
		0.42	0.55	750	29.53	392	864	3	C	C	C	C	C	C	
	Heavy duty	0.54	0.71	900	35.43	440	971	4	C	C	C	C	C	C	
		0.25	0.33	450	17.72	320	705	3	D	D	D	D	D	D	
		0.33	0.43	600	23.62	352	777	3	D	D	D	D	D	D	
		0.42	0.55	750	29.53	384	848	3	D	D	D	D	D	D	
		0.54	0.71	900	35.43	445	981	4	D	D	D	D	D	D	

Please consult with your Volvo dealer for the proper match of buckets and attachments to suit the application.

The recommendations are given as a guide only, based on typical operation conditions.

Bucket capacity based on ISO 7451, heaped material with a 1:1 angle of repose.

Maximum material density

	kg/m ³	lb/yd ³	
A	1 200 - 1 300	2,000 - 2,200	Coal, Caliche, Shale
B	1 400 - 1 600	2,300 - 2,700	Wet earth and clay, Limestone, Sandstone
C	1 700 - 1 800	2,800 - 3,100	Granite, Wet sand, Well blasted rock
D	> 1 900	> 3,200	Wet mud, Iron ore

Specifications.

LIFTING CAPACITY EC140EL without dozer blade

Lifting capacity at the arm end without bucket.

For lifting capacity including bucket, simply subtract actual weight of the direct fit bucket or the bucket with quick coupler from the following values.

	Lifting hook related to ground level	1.5 m, 5 ft		3.0 m, 10 ft		4.5 m, 15 ft		6.0 m, 20 ft		Max. Reach		
		Along UC	Across UC	Along UC	Across UC	Along UC	Across UC	Along UC	Across UC	Along UC	Across UC	
Boom: 4.6 m / 15' 1" Arm: 2.1 m / 6' 11" Shoe: 600 mm / 24" CWT: 2 100 kg / 4,630 lb	6 m kg	-	-	-	-	*3 320	*3 320	-	-	*3 500	3 390	4.9 m
	20 ft lb	-	-	-	-	*7,470	*7,470	-	-	*7,730	7,710	15.8 ft
	4.5 m kg	-	-	-	-	*3 470	*3 470	-	-	*3 570	2 450	6.0 m
	15 ft lb	-	-	-	-	*7,600	*7,600	-	-	*7,850	5,470	19.5 ft
	3 m kg	-	-	*6 230	*6 230	*4 330	3 700	3 710	2 410	3 220	2 090	6.5 m
	10 ft lb	-	-	*13,270	*13,270	*9,380	7,950	7,950	5,160	7,130	4,620	21.4 ft
	1.5 m kg	-	-	-	-	*5 390	3 490	3 620	2 320	3 040	1 960	6.7 m
	5 ft lb	-	-	-	-	*11,650	7,490	7,770	4,990	6,710	4,320	22.0 ft
	0 m kg	-	-	*5 400	*5 400	5 460	3 350	3 550	2 260	3 120	2 000	6.5 m
	0 ft lb	-	-	*12,670	*12,670	11,680	7,190	7,620	4,850	6,890	4,410	21.5 ft
	-1.5 m kg	*5 010	*5 010	*9 440	6 080	5 410	3 310	-	-	3 540	2 250	6.0 m
	-5 ft lb	*11,310	*11,310	*20,480	13,010	11,590	7,110	-	-	7,830	4,980	19.6 ft
	-3 m kg	-	-	*8 220	6 200	*5 470	3 380	-	-	4 800	3 000	4.9 m
	-10 ft lb	-	-	*17,740	13,280	*11,710	7,270	-	-	*10,660	6,710	16.0 ft
Boom: 4.6 m / 15' 1" Arm: 2.5 m / 8' 2" Shoe: 600 mm / 24" CWT: 2 100 kg / 4,630 lb	6 m kg	-	-	-	-	*2 840	*2 840	-	-	*3 210	2 920	5.4 m
	20 ft lb	-	-	-	-	*6,350	*6,350	-	-	*7,080	6,600	17.5 ft
	4.5 m kg	-	-	-	-	*3 080	*3 080	*3 190	2 470	*3 170	2 210	6.4 m
	15 ft lb	-	-	-	-	*6,740	*6,740	*7,080	5,310	*7,000	4,920	20.9 ft
	3 m kg	-	-	*5 330	*5 330	*3 950	3 720	*3 490	2 410	2 950	1 910	6.9 m
	10 ft lb	-	-	*11,370	*11,370	*8,570	8,030	*7,630	5,190	6,520	4,230	22.7 ft
	1.5 m kg	-	-	-	-	*5 070	3 490	3 600	2 310	2 790	1 800	7.1 m
	5 ft lb	-	-	*16,030	13,570	*10,980	7,530	7,770	4,980	6,170	3,970	23.3 ft
	0 m kg	-	-	*5 970	*5 970	5 420	3 320	3 520	2 230	2 850	1 820	6.9 m
	0 ft lb	-	-	*13,890	12,940	11,670	7,170	7,580	4,820	6,300	4,030	22.7 ft
	-1.5 m kg	*4 550	*4 550	*9 610	5 980	5 350	3 260	3 480	2 200	3 180	2 020	6.4 m
	-5 ft lb	*10,250	*10,250	*20,840	12,870	11,510	7,030	7,520	4,760	7,030	4,470	21.0 ft
	-3 m kg	*8 940	*8 940	*8 690	6 080	5 390	3 300	-	-	4 080	2 570	5.4 m
	-10 ft lb	*20,220	*20,220	*18,770	13,070	11,610	7,120	-	-	9,120	5,730	17.7 ft
Boom: 4.6 m / 15' 1" Arm: 3.0 m / 9' 10" Shoe: 600 mm / 24" CWT: 2 100 kg / 4,630 lb	6 m kg	-	-	-	-	-	-	*2 860	2 490	*2 810	2 460	6.0 m
	20 ft lb	-	-	-	-	-	-	-	-	*6,250	5,540	19.6 ft
	4.5 m kg	-	-	-	-	-	-	*2 780	2 490	*2 640	1 940	6.9 m
	15 ft lb	-	-	-	-	-	-	*6,140	5,360	*5,830	4,310	22.7 ft
	3 m kg	-	-	-	-	*3 440	*3 440	*3 140	2 410	*2 630	1 700	7.4 m
	10 ft lb	-	-	-	-	*7,460	*7,460	*6,870	5,190	*5,800	3,760	24.3 ft
	1.5 m kg	-	-	*7 320	6 420	*4 620	3 500	3 600	2 300	2 510	1 600	7.6 m
	5 ft lb	-	-	*15,710	13,840	*10,010	7,560	7,750	4,960	5,540	3,540	24.9 ft
	0 m kg	-	-	*6 510	5 990	5 410	3 300	3 490	2 200	2 550	1 620	7.4 m
	0 ft lb	-	-	*15,160	12,890	11,630	7,120	7,520	4,750	5,620	3,570	24.4 ft
	-1.5 m kg	*3 990	*3 990	*8 760	5 880	5 290	3 200	3 430	2 150	2 790	1 760	6.9 m
	-5 ft lb	*8,970	*8,970	*20,130	12,650	11,380	6,910	7,390	4,630	6,170	3,900	22.7 ft
	-3 m kg	*7 370	*7 370	*9 080	5 930	5 300	3 210	3 460	2 170	3 420	2 150	6.0 m
	-10 ft lb	*16,640	*16,640	*19,640	12,760	11,400	6,920	-	-	7,620	4,790	19.7 ft
-4.5 m kg	-	-	*7 210	6 140	-	-	-	-	*4 480	3 360	4.5 m	
-15 ft lb	-	-	*15,330	13,220	-	-	-	-	*9,920	7,690	14.4 ft	
Boom: 4.6 m / 15' 1" Arm: 2.1 m / 6' 11" Shoe: 600 mm / 24" CWT: 2 450 kg / 5,400 lb	6 m kg	-	-	-	-	*3 320	*3 320	-	-	*3 500	*3 500	4.9 m
	20 ft lb	-	-	-	-	*7,470	*7,470	-	-	*7,730	*7,730	15.8 ft
	4.5 m kg	-	-	-	-	*3 470	*3 470	-	-	*3 570	2 610	6.0 m
	15 ft lb	-	-	-	-	*7,600	*7,600	-	-	*7,850	5,820	19.5 ft
	3 m kg	-	-	*6 230	*6 230	*4 330	3 910	*3 750	2 550	3 400	2 230	6.5 m
	10 ft lb	-	-	*13,270	*13,270	*9,380	8,440	*8,210	5,500	7,530	4,940	21.4 ft
	1.5 m kg	-	-	-	-	*5 390	3 700	3 800	2 470	3 220	2 100	6.7 m
	5 ft lb	-	-	-	-	*11,650	7,990	8,200	5,330	7,100	4,630	22.0 ft
	0 m kg	-	-	*5 400	*5 400	5 730	3 560	3 730	2 410	3 300	2 140	6.5 m
	0 ft lb	-	-	*12,670	*12,670	12,340	7,690	8,050	5,200	7,280	4,720	21.5 ft
	-1.5 m kg	*5 010	*5 010	*9 440	6 460	5 690	3 520	-	-	3 740	2 410	6.0 m
	-5 ft lb	*11,310	*11,310	*20,480	13,880	12,240	7,610	-	-	8,280	5,330	19.6 ft
	-3 m kg	-	-	*8 220	6 580	*5 470	3 590	-	-	*4 820	3 200	4.9 m
	-10 ft lb	-	-	*17,740	14,150	*11,710	7,770	-	-	*10,660	7,160	16.0 ft

Notes: 1. Machine in "Fine Mode-F" (Power Boost) for lifting capacities. 2. The above loads are in compliance with SAE J1097 and ISO 10567 Hydraulic Excavator Lifting Capacity Standards. 3. Rated loads do not exceed 87% of hydraulic lifting capacity or 75% of tipping load. 4. Rated loads marked with an asterisk (*) are limited by hydraulic capacity rather than tipping load.

LIFTING CAPACITY EC140EL without dozer blade

Lifting capacity at the arm end without bucket.

For lifting capacity including bucket, simply subtract actual weight of the direct fit bucket or the bucket with quick coupler from the following values.

	Lifting hook related to ground level	1.5 m, 5 ft		3.0 m, 10 ft		4.5 m, 15 ft		6.0 m, 20 ft		Max. Reach			
		Along UC	Across UC	Along UC	Across UC	Along UC	Across UC	Along UC	Across UC	Along UC	Across UC		
Boom: 4.6 m / 15' 1" Arm: 2.5 m / 8' 2" Shoe: 600 mm / 24" CWT: 2 450 kg / 5,400 lb	6 m	kg	-	-	-	-	*2 840	*2 840	-	-	*3 210	3 100	5.4 m
	20 ft	lb	-	-	-	-	*6,350	*6,350	-	-	*7,080	7,010	17.5 ft
	4.5 m	kg	-	-	-	-	*3 080	*3 080	*3 190	2 630	*3 170	2 350	6.4 m
	15 ft	lb	-	-	-	-	*6,740	*6,740	*7,080	5,660	*7,000	5,250	20.9 ft
	3 m	kg	-	-	*5 330	*5 330	*3 950	3 950	*3 490	2 560	*3 110	2 040	6.9 m
	10 ft	lb	-	-	*11,370	*11,370	*8,570	8,520	*7,630	5,530	6,890	4,520	22.7 ft
	1.5 m	kg	-	-	-	-	*5 070	3 720	3 810	2 470	2 960	1 930	7.1 m
	5 ft	lb	-	-	*16,030	14,450	*10,980	8,020	8,200	5,330	6,530	4,260	23.3 ft
	0 m	kg	-	-	*5 970	*5 970	5 730	3 550	3 720	2 390	3 020	1 960	6.9 m
	0 ft	lb	-	-	*13,890	13,820	12,320	7,670	8,020	5,160	6,670	4,320	22.7 ft
	-1.5 m	kg	*4 550	*4 550	*9 610	6 390	5 650	3 490	3 690	2 360	3 360	2 170	6.4 m
	-5 ft	lb	*10,250	*10,250	*20,840	13,740	12,170	7,530	7,950	5,100	7,440	4,790	21.0 ft
	-3 m	kg	*8 940	*8 940	*8 690	6 480	5 700	3 520	-	-	4 320	2 750	5.4 m
	-10 ft	lb	*20,220	*20,220	*18,770	13,940	12,260	7,610	-	-	9,630	6,130	17.7 ft
Boom: 4.6 m / 15' 1" Arm: 3.0 m / 9' 10" Shoe: 600 mm / 24" CWT: 2 450 kg / 5,400 lb	6 m	kg	-	-	-	-	-	*2 860	2 650	*2 810	2 620	6.0 m	
	20 ft	lb	-	-	-	-	-	-	-	*6,250	5,890	19.6 ft	
	4.5 m	kg	-	-	-	-	-	-	*2 780	2 650	*2 640	2 070	6.9 m
	15 ft	lb	-	-	-	-	-	-	*6,140	5,710	*5,830	4,610	22.7 ft
	3 m	kg	-	-	-	-	*3 440	*3 440	*3 140	2 570	*2 630	1 820	7.4 m
	10 ft	lb	-	-	-	-	*7,460	*7,460	*6,870	5,540	*5,800	4,030	24.3 ft
	1.5 m	kg	-	-	*7 320	6 830	*4 620	3 730	*3 680	2 460	2 660	1 720	7.6 m
	5 ft	lb	-	-	*15,710	14,710	*10,010	8,060	*8,020	5,300	5,870	3,800	24.9 ft
	0 m	kg	-	-	*6 510	6 400	*5 620	3 530	3 690	2 360	2 700	1 740	7.4 m
	0 ft	lb	-	-	*15,160	13,760	*12,180	7,610	7,950	5,090	5,960	3,840	24.4 ft
	-1.5 m	kg	*3 990	*3 990	*8 760	6 290	5 600	3 430	3 630	2 310	2 960	1 900	6.9 m
	-5 ft	lb	*8,970	*8,970	*20,130	13,520	12,040	7,400	7,830	4,980	6,540	4,190	22.7 ft
	-3 m	kg	*7 370	*7 370	*9 080	6 340	5 600	3 430	3 660	2 330	3 620	2 310	6.0 m
	-10 ft	lb	*16,640	*16,640	*19,640	13,630	12,050	7,410	-	-	8,060	5,140	19.7 ft
-4.5 m	kg	-	-	*7 210	6 540	-	-	-	-	*4 480	3 590	4.5 m	
-15 ft	lb	-	-	*15,330	14,100	-	-	-	-	*9,920	8,210	14.4 ft	

Notes: 1. Machine in "Fine Mode-F" (Power Boost) for lifting capacities. 2. The above loads are in compliance with SAE J1097 and ISO 10567 Hydraulic Excavator Lifting Capacity Standards. 3. Rated loads do not exceed 87% of hydraulic lifting capacity or 75% of tipping load. 4. Rated loads marked with an asterisk (*) are limited by hydraulic capacity rather than tipping load.

Specifications.

LIFTING CAPACITY EC140EL with dozer blade

Lifting capacity at the arm end without bucket.

For lifting capacity including bucket, simply subtract actual weight of the direct fit bucket or the bucket with quick coupler from the following values.

	Lifting hook related to ground level	1.5 m, 5 ft		3.0 m, 10 ft		4.5 m, 15 ft		6.0 m, 20 ft		Max. Reach		
		Along UC	Across UC	Along UC	Across UC	Along UC	Across UC	Along UC	Across UC	Along UC	Across UC	
Boom: 4.6 m / 15' 1" Arm: 2.1 m / 6' 11" Shoe: 600 mm / 24" CWT: 2 100 kg / 4,630 lb	6 m kg	-	-	-	-	*3 320	*3 320	-	-	*3 500	*3 500	4.9 m
	20 ft lb	-	-	-	-	*7,470	*7,470	-	-	*7,730	*7,730	15.8 ft
	4.5 m kg	-	-	-	-	*3 470	*3 470	-	-	*3 570	2 770	6.0 m
	15 ft lb	-	-	-	-	*7,600	*7,600	-	-	*7,850	6,170	19.5 ft
	3 m kg	-	-	*6 230	*6 230	*4 330	4 160	*3 750	2 710	*3 710	2 370	6.5 m
	10 ft lb	-	-	*13,270	*13,270	*9,380	8,980	*8,210	5,840	*8,170	5,240	21.4 ft
	1.5 m kg	-	-	-	-	*5 390	3 950	*4 170	2 630	*3 910	2 230	6.7 m
	5 ft lb	-	-	-	-	*11,650	8,520	*9,100	5,670	*8,610	4,920	22.0 ft
	0 m kg	-	-	*5 400	*5 400	*6 100	3 810	*4 520	2 560	*4 160	2 280	6.5 m
	0 ft lb	-	-	*12,670	*12,670	*13,220	8,210	*9,820	5,530	*9,170	5,020	21.5 ft
	-1.5 m kg	*5 010	*5 010	*9 440	6 990	*6 220	3 770	-	-	*4 470	2 560	6.0 m
	-5 ft lb	*11,310	*11,310	*20,480	15,020	*13,490	8,130	-	-	*9,870	5,670	19.6 ft
	-3 m kg	-	-	*8 220	7 120	*5 470	3 840	-	-	*4 820	3 410	4.9 m
	-10 ft lb	-	-	*17,740	15,300	*11,710	8,290	-	-	*10,660	7,640	16.0 ft
	Boom: 4.6 m / 15' 1" Arm: 2.5 m / 8' 2" Shoe: 600 mm / 24" CWT: 2 100 kg / 4,630 lb	6 m kg	-	-	-	-	*2 840	*2 840	-	-	*3 210	*3 210
20 ft lb		-	-	-	-	*6,350	*6,350	-	-	*7,080	*7,080	17.5 ft
4.5 m kg		-	-	-	-	*3 080	*3 080	*3 190	2 790	*3 170	2 500	6.4 m
15 ft lb		-	-	-	-	*6,740	*6,740	*7,080	6,000	*7,000	5,560	20.9 ft
3 m kg		-	-	*5 330	*5 330	*3 950	*3 950	*3 490	2 720	*3 160	2 170	6.9 m
10 ft lb		-	-	*11,370	*11,370	*8,570	*8,570	*7,630	5,870	*6,970	4,800	22.7 ft
1.5 m kg		-	-	-	-	*5 070	3 960	*3 970	2 620	*3 340	2 050	7.1 m
5 ft lb		-	-	*16,030	15,610	*10,980	8,560	*8,660	5,660	*7,360	4,520	23.3 ft
0 m kg		-	-	*5 970	*5 970	*5 920	3 800	*4 400	2 540	*3 740	2 080	6.9 m
0 ft lb		-	-	*13,890	*13,890	*12,830	8,190	*9,560	5,490	*8,260	4,600	22.7 ft
-1.5 m kg		*4 550	*4 550	*9 610	6 930	*6 220	3 730	*4 520	2 510	*4 150	2 310	6.4 m
-5 ft lb		*10,250	*10,250	*20,840	14,880	*13,470	8,050	*9,780	5,430	*9,180	5,100	21.0 ft
-3 m kg		*8 940	*8 940	*8 690	7 020	*5 770	3 770	-	-	*4 510	2 930	5.4 m
-10 ft lb		*20,220	*20,220	*18,770	15,090	*12,430	8,140	-	-	*9,960	6,540	17.7 ft
Boom: 4.6 m / 15' 1" Arm: 3.0 m / 9' 10" Shoe: 600 mm / 24" CWT: 2 100 kg / 4,630 lb		6 m kg	-	-	-	-	-	-	*2 860	2 810	*2 810	2 770
	20 ft lb	-	-	-	-	-	-	-	-	*6,250	6,240	19.6 ft
	4.5 m kg	-	-	-	-	-	-	*2 780	*2 780	*2 640	2 200	6.9 m
	15 ft lb	-	-	-	-	-	-	*6,140	6,050	*5,830	4,890	22.7 ft
	3 m kg	-	-	-	-	*3 440	*3 440	*3 140	2 730	*2 630	1 930	7.4 m
	10 ft lb	-	-	-	-	*7,460	*7,460	*6,870	5,880	*5,800	4,280	24.3 ft
	1.5 m kg	-	-	*7 320	*7 320	*4 620	3 980	*3 680	2 610	*2 760	1 830	7.6 m
	5 ft lb	-	-	*15,710	*15,710	*10,010	8,590	*8,020	5,640	*6,070	4,050	24.9 ft
	0 m kg	-	-	*6 510	*6 510	*5 620	3 770	*4 190	2 510	*3 040	1 850	7.4 m
	0 ft lb	-	-	*15,160	14,910	*12,180	8,140	*9,110	5,420	*6,700	4,090	24.4 ft
	-1.5 m kg	*3 990	*3 990	*8 760	6 820	*6 110	3 670	*4 460	2 460	*3 590	2 020	6.9 m
	-5 ft lb	*8,970	*8,970	*20,130	14,660	*13,240	7,920	*9,680	5,310	*7,960	4,470	22.7 ft
	-3 m kg	*7 370	*7 370	*9 080	6 880	*5 950	3 680	*4 160	2 480	*4 100	2 460	6.0 m
	-10 ft lb	*16,640	*16,640	*19,640	14,780	*12,860	7,940	-	-	*9,070	5,480	19.7 ft
	-4.5 m kg	-	-	*7 210	7 090	-	-	-	-	*4 480	3 840	4.5 m
-15 ft lb	-	-	*15,330	15,260	-	-	-	-	*9,920	8,780	14.4 ft	
Boom: 4.6 m / 15' 1" Arm: 2.1 m / 6' 11" Shoe: 600 mm / 24" CWT: 2 450 kg / 5,400 lb	6 m kg	-	-	-	-	*3 320	*3 320	-	-	*3 500	*3 500	4.9 m
	20 ft lb	-	-	-	-	*7,470	*7,470	-	-	*7,730	*7,730	15.8 ft
	4.5 m kg	-	-	-	-	*3 470	*3 470	-	-	*3 570	2 930	6.0 m
	15 ft lb	-	-	-	-	*7,600	*7,600	-	-	*7,850	6,540	19.5 ft
	3 m kg	-	-	*6 230	*6 230	*4 330	*4 330	*3 750	2 870	*3 710	2 520	6.5 m
	10 ft lb	-	-	*13,270	*13,270	*9,380	*9,380	*8,210	6,200	*8,170	5,570	21.4 ft
	1.5 m kg	-	-	-	-	*5 390	4 180	*4 170	2 790	*3 910	2 370	6.7 m
	5 ft lb	-	-	-	-	*11,650	9,030	*9,100	6,020	*8,610	5,240	22.0 ft
	0 m kg	-	-	*5 400	*5 400	*6 100	4 040	*4 520	2 730	*4 160	2 420	6.5 m
	0 ft lb	-	-	*12,670	*12,670	*13,220	8,730	*9,820	5,890	*9,170	5,350	21.5 ft
	-1.5 m kg	*5 010	*5 010	*9 440	7 420	*6 220	4 010	-	-	*4 470	2 730	6.0 m
	-5 ft lb	*11,310	*11,310	*20,480	15,950	*13,490	8,640	-	-	*9,870	6,040	19.6 ft
	-3 m kg	-	-	*8 220	7 550	*5 470	4 070	-	-	*4 820	3 630	4.9 m
	-10 ft lb	-	-	*17,740	16,230	*11,710	8,810	-	-	*10,660	8,110	16.0 ft

Notes: 1. Machine in "Fine Mode-F" (Power Boost) for lifting capacities. 2. The above loads are in compliance with SAE J1097 and ISO 10567 Hydraulic Excavator Lifting Capacity Standards. 3. Rated loads do not exceed 87% of hydraulic lifting capacity or 75% of tipping load. 4. Rated loads marked with an asterisk (*) are limited by hydraulic capacity rather than tipping load.

LIFTING CAPACITY EC140EL with dozer blade

Lifting capacity at the arm end without bucket.

For lifting capacity including bucket, simply subtract actual weight of the direct fit bucket or the bucket with quick coupler from the following values.

	Lifting hook related to ground level	1.5m, 5 ft		3.0m, 10 ft		4.5m, 15 ft		6.0m, 20 ft		Max. Reach		
		Along UC	Across UC	Along UC	Across UC	Along UC	Across UC	Along UC	Across UC	Along UC	Across UC	
Boom: 4.6 m / 15' 1" Arm: 2.5 m / 8' 2" Shoe: 600 mm / 24" CWT: 2 450 kg / 5,400 lb	6 m kg	-	-	-	-	*2 840	*2 840	-	-	*3 210	*3 210	5.4 m
	20 ft lb	-	-	-	-	*6,350	*6,350	-	-	*7,080	*7,080	17.5 ft
	4.5 m kg	-	-	-	-	*3 080	*3 080	*3 190	2 950	*3 170	2 650	6.4 m
	15 ft lb	-	-	-	-	*6,740	*6,740	*7,080	6,350	*7,000	5,900	20.9 ft
	3 m kg	-	-	*5 330	*5 330	*3 950	*3 950	*3 490	2 890	*3 160	2 310	6.9 m
	10 ft lb	-	-	*11,370	*11,370	*8,570	*8,570	*7,630	6,220	*6,970	5,110	22.7 ft
	1.5 m kg	-	-	-	-	*5 070	4 200	*3 970	2 790	*3 340	2 180	7.1 m
	5 ft lb	-	-	*16,030	*16,030	*10,980	9,070	*8,660	6,020	*7,360	4,820	23.3 ft
	0 m kg	-	-	*5 970	*5 970	*5 920	4 040	*4 400	2 710	*3 740	2 220	6.9 m
	0 ft lb	-	-	*13,890	*13,890	*12,830	8,710	*9,560	5,850	*8,260	4,900	22.7 ft
	-1.5 m kg	*4 550	*4 550	*9 610	7 360	*6 220	3 970	*4 520	2 680	*4 150	2 460	6.4 m
	-5 ft lb	*10,250	*10,250	*20,840	15,800	*13,470	8,570	*9,780	5,790	*9,180	5,440	21.0 ft
	-3 m kg	*8 940	*8 940	*8 690	7 450	*5 770	4 010	-	-	*4 510	3 120	5.4 m
	-10 ft lb	*20,220	*20,220	*18,770	16,010	*12,430	8,650	-	-	*9,960	6,950	17.7 ft
	Boom: 4.6 m / 15' 1" Arm: 3.0 m / 9' 10" Shoe: 600 mm / 24" CWT: 2 450 kg / 5,400 lb	6 m kg	-	-	-	-	-	-	*2 860	*2 860	*2 810	*2 810
20 ft lb		-	-	-	-	-	-	-	-	*6,250	*6,250	19.6 ft
4.5 m kg		-	-	-	-	-	-	*2 780	*2 780	*2 640	2 330	6.9 m
15 ft lb		-	-	-	-	-	-	*6,140	*6,140	*5,830	5,190	22.7 ft
3 m kg		-	-	-	-	*3 440	*3 440	*3 140	2 890	*2 630	2 060	7.4 m
10 ft lb		-	-	-	-	*7,460	*7,460	*6,870	6,230	*5,800	4,560	24.3 ft
1.5 m kg		-	-	*7 320	*7 320	*4 620	4 220	*3 680	2 780	*2 760	1 960	7.6 m
5 ft lb		-	-	*15,710	*15,710	*10,010	9,110	*8,020	5,990	*6,070	4,320	24.9 ft
0 m kg		-	-	*6 510	*6 510	*5 620	4 010	*4 190	2 680	*3 040	1 980	7.4 m
0 ft lb		-	-	*15,160	*15,160	*12,180	8,660	*9,110	5,780	*6,700	4,370	24.4 ft
-1.5 m kg		*3 990	*3 990	*8 760	7 250	*6 110	3 910	*4 460	2 620	*3 590	2 160	6.9 m
-5 ft lb		*8,970	*8,970	*20,130	15,580	*13,240	8,440	*9,680	5,670	*7,960	4,770	22.7 ft
-3 m kg		*7 370	*7 370	*9 080	7 310	*5 950	3 920	*4 160	2 650	*4 100	2 620	6.0 m
-10 ft lb		*16,640	*16,640	*19,640	15,700	*12,860	8,450	-	-	*9,070	5,840	19.7 ft
-4.5 m kg		-	-	*7 210	*7 210	-	-	-	-	*4 480	4 080	4.5 m
-15 ft lb	-	-	*15,330	*15,330	-	-	-	-	*9,920	9,330	14.4 ft	

Notes: 1. Machine in "Fine Mode-F" (Power Boost) for lifting capacities. 2. The above loads are in compliance with SAE J1097 and ISO 10567 Hydraulic Excavator Lifting Capacity Standards. 3. Rated loads do not exceed 87% of hydraulic lifting capacity or 75% of tipping load. 4. Rated loads marked with an asterisk (*) are limited by hydraulic capacity rather than tipping load.

Equipment.

STANDARD EQUIPMENT

Engine

Turbocharged, 4 stroke diesel engine with water cooling, direct injection and charged air cooler that meets Tier 4f EU (Stage IV) requirements

Air filter with indicator

Air intake heater

Cyclone pre-cleaner

Electric engine shut-off

Fuel filter and water separator

Alternator, 80 A

Tropical cooling system (50 deg. C)

Electric/Electronic control system

Contronics

Advanced mode control system

Self-diagnostic system

Machine status indication

GSM/GPS Caretrack and 3yr-Caretrack subscription

Engine speed sensing power control

Automatic idling system

One-touch power boost

Safety stop/start function

Adjustable LCD color monitor

Master electrical disconnect switch

Engine restart prevention circuit

High-capacity halogen or LED lights:

Halogen

Frame-mounted: 2, Boom-mounted: 1

LED

Frame-mounted: 2, Boom-mounted: 2

Travel alarm

Batteries, 2 x 12 V/100 Ah

Start motor, 24 V/5.5 kW

Hydraulic system

Boom float function without HRV

Straight travel pedal

Pilot control pattern change

Automatic sensing hydraulic system

Summation system

Boom priority

Arm priority

Swing priority

ECO mode fuel saving technology

Boom, arm and bucket regeneration valves

Swing anti-rebound valves

Boom and arm holding valves

Multi-stage filtering system

Boom cylinders (x2)

Cylinder cushioning

Cylinder contamination seals

Auxiliary hydraulic valve

Automatic two-speed travel motors

Hydraulic oil, 46

Frame

Access way with handrail

Tool storage area

Punched metal anti-slip plates

Heavy duty lower cover plates

2 450 kg / 5,400 lb counterweight

Cab and interior

ROPS (ISO12117-2) certified cab

Silicon oil and rubber mounts with spring

Control lock out lever

Travel pedals and hand levers

Adjustable operator seat with heater

Control joysticks with 4 switches each

Heater & air-conditioner, automatic

Flexible antenna

Radio with MP3, USB port, and Bluetooth

Cab, all-weather sound suppressed, includes:

Cup holders

Door locks

Tinted glass

Floor mat

Horn

Large storage area

Pull-up type front window

Removable lower windshield

Seat belt

Safety glass

Sun screens, front, roof, rear

Windshield wiper with intermittent feature

Rear view camera

Master key

Undercarriage

Heavy duty belly cover plates

Hydraulic track adjusters

Greased and sealed track link

Track Guard

600 mm/24" with triple grousers

Digging equipment

4.6 m/15' 1" mono boom

2.5 m/8' 2" arm

Linkage

Manual centralized lubrication

OPTIONAL EQUIPMENT

Engine

Block heater: 120 V

Diesel coolant heater, 5 kW

Water separator with heater

Auto engine shutdown

Standard cooling system by fan clutch(40 deg. C)

Fuel filler pump: 30 l/min/9 gpm

Electric

Extra work lights (Halogen or LED):

Cab-mounted 3

Counterweight-mounted 1

Anti-theft system

Rotating warning beacon

OPTIONAL EQUIPMENT

Hydraulic system

Boom hose rupture valve with overload warning device

Arm hose rupture valve

Boom float function with HRV

Hydraulic piping:

Work tool management system (up to 20 programmable memories)

Breaker & shear, 1 and 2 pump flow

Slope & rotator (40 lpm/11 gpm or 60 lpm/16 gpm)

Extra for slope & rotator

Grapple

Oil leak (drain) line

Quick coupler

Breaker & shear pressure pre-setting

Volvo hydraulic quick coupler S6, S6 without hook

Volvo hydraulic quick coupler VQC-HU,DR14 / RQC-HD

Hydraulic oil, biodegradable 46

Hydraulic oil, ISO VG 32,46, 68

Hydraulic oil, longlife oil 32, 68

Cab and interior

Fabric seat without heater

Fabric seat with heater and air suspension

Control joysticks with semi-long

Control joysticks with 3 switch & 1 proportional

Opening top hatch

Cab and interior

Cab-mounted falling object guard (FOG)

Cab-mounted falling object protective structure (FOPS)

Rain shield

Side view camera

Smoker kit (ashtray and lighter)

Safety net for front window

Sunlight protection, roof (steel)

Lower wiper with intermittent control

Anti-vandalism kit

Specific key

Frame

2 100 kg / 4,630 lb counterweight

Undercarriage

Dozer blade

Full track guard

500 mm/20", 600 mm/24", 600 mm/24" HD,
700 mm/28", 750 mm/30" shoe with triple grousers
and 500 mm/20" with rubber grousers

Digging equipment

4.6 m/15' 1" 2-piece boom

2.1 m/6' 11", 3.0 m/9' 11" arm

Linkage with lifting eye

Service

Tool kit, daily maintenance

Tool kit, full scale

Selection of Volvo optional equipment

Auto engine shutdown**Two-piece boom****Diesel coolant heater****LED lights****Fuel fill pump****Dozer blade**

Not all products are available in all markets. Under our policy of continuous improvement, we reserve the right to change specifications and design without prior notice. The illustrations do not necessarily show the standard version of the machine.

VOLVO

Volvo Construction Equipment

www.volvoce.com