



Volvo Construction Equipment

EC160E

VOLVO EXCAVATORS 16.5-20.7 t / 36,266-45,592 lb 148 hp



A passion for performance.

At Volvo Construction Equipment, we're not just coming along for the ride. Developing products and services that raise productivity – we are confident we can lower costs and increase profits for customers around the globe. Part of the Volvo Group, we are passionate about innovative solutions to help you work smarter – not harder.

Helping you to do more

Doing more with less is a trademark of Volvo Construction Equipment. High productivity has long been married to low energy consumption, ease of use and durability. When it comes to lowering life-cycle costs, Volvo is in a class of its own.

Designed to fit your needs

There is a lot riding on creating solutions that are suited to the particular needs of different industry applications. Innovation often involves high technology – but it doesn't always have to. Some of our best ideas have been simple, based on a clear and deep understanding of our customers' working lives.



You learn a lot in 180 years

Over the years, Volvo has advanced solutions that have revolutionized the use of construction equipment. No other name speaks Safety louder than Volvo. Protecting operators, those around them and minimizing our environmental impact are traditional values that continue to shape our product design philosophy.

We're on your side

We back the Volvo brand with the best people. Volvo is truly a global enterprise, one that is on standby to support customers quickly and efficiently – wherever they are.

We have a passion for performance.

A strong, dedicated, capable dealer network.

Our dealers are strategically located throughout North America to provide the equipment you need and the parts and service support you demand for a productive and profitable operation.

The strength of our dealer network is enhanced with extensive individualized product support training at our best-in-class Customer Center in Shippensburg and through hands-on training. Using a great Product Demonstration Center featuring a dedicated area for most common applications, visitors operate equipment from our entire product line under a variety of simulated working conditions. This facility is in year-round use by our dealers and customers.

Building the best starts right here.

The products designed and manufactured by Volvo Construction Equipment have their beginnings at the most advanced Research & Design centers in the industry. Volvo CE machines are designed in 11 R&D centers and produced in 15 manufacturing facilities across the world.

The major R&D center and manufacturing plant in the Americas is located in Shippensburg, Pennsylvania. This facility has been in operation for over 30 years and – with its recently added 200,000 sq. ft. expansion – now covers 570,000 sq. ft. on an 80 acre campus. Dedicated work teams and highly advanced technologies and techniques using the Volvo Production System ensure continuous quality improvements, labor savings and cost control to reach the high quality that our customers have come to expect from Volvo.





Volvo Trucks



Renault Trucks



Mack Trucks



UD Trucks



Volvo Buses



Volvo Construction Equipment



Volvo Penta



Volvo Financial Services

Effortless Efficiency.

Volvo's new EC160E provides a range of new features to ensure efficiency is a key priority. By carefully considering every duty and component, a machine has been produced that incorporates maximum uptime while also reducing fuel consumption and cycle times – all while delivering elite performance.

Volvo engine

Featuring proven advanced technology, and built on decades of experience, Volvo's robust D4 Tier 4 Final engine boasts more power - while reducing both fuel consumption and emissions to deliver superior quality, reliability and durability.



Boom float function

With the boom float function, the pump flow for boom lowering can be saved or used for other functions, reducing the cycle time. Also, the grading operation can be made easier.

Auto engine shutdown

To reduce fuel consumption, the engine will automatically switch off when the machine is inactive for a pre-set amount of time (five minutes is the default setting).

Increased power

The increased engine power combined with the increased pump flow creates a highly responsive combined operation and travel. It also produces faster cycle times and low fuel consumption which leads to higher productivity.

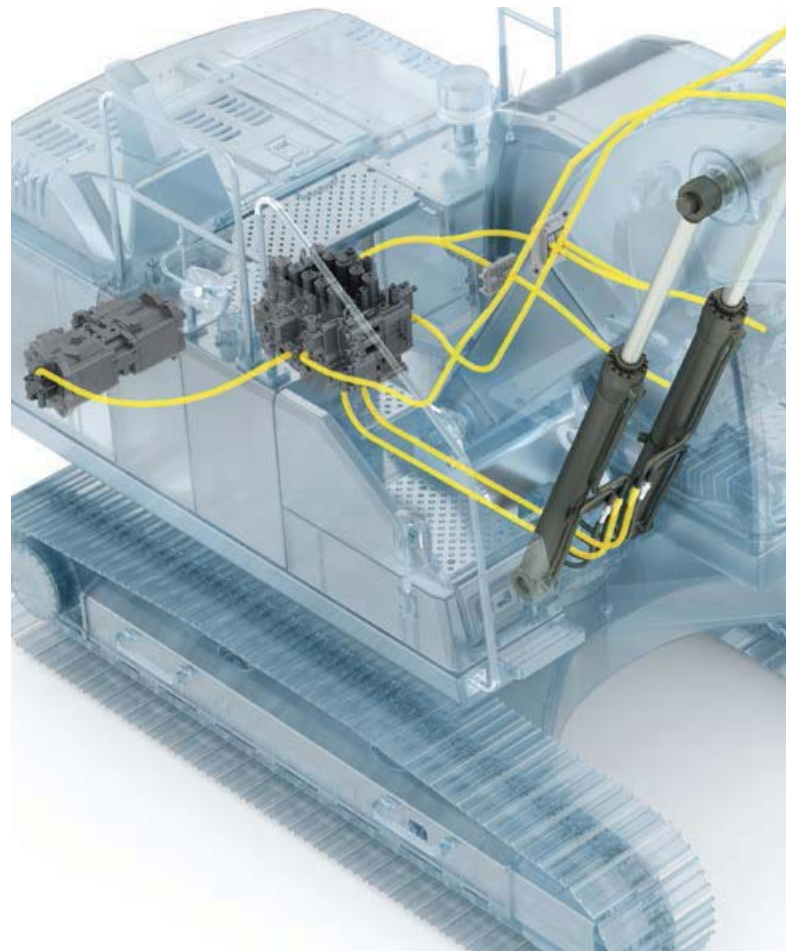

Main Control Valve and Software

This valve is compatible with software in the machine – building on the already superior controllability by providing a smooth and easy operation. It is also compatible with Volvo's ECO mode – this provides electronic pump control to enhance fuel efficiency.



Optimized hydraulics system

The hydraulics system, combined with the fully electronic control system and advanced ECO mode, has been optimized to work in harmony with D4 Tier 4 Final engine to match the engine power, reduce power loss and improve controllability and response time.



Human Machine Interface (HMI)

All machine interfaces – including joysticks, keypad, panel and larger LCD monitor – are ergonomically designed for optimum control and efficiency, resulting in increased productivity and operator comfort. The number of switches have been simplified and climate control integrated into the keypad for easy adjustments.

Making hard work easy.

The EC160E has been ergonomically designed for convenience and ease of use, allowing the operator to take control in comfort. The spacious cab design, controls and features increase productivity by ensuring the machine takes the strain and not the operator.

Side view camera

As well as the rear view camera, there is now a side view camera option to cover the visual blind spot. Both views are displayed on the color monitor, creating a safer working environment, protecting the operator and personnel on the ground.



Short-cut key

For added convenience, functions such as windshield wipers, cameras, auto-mute function can all be assigned a short-cut button on the joystick. This allows the operator to select a function during the application without disruption.

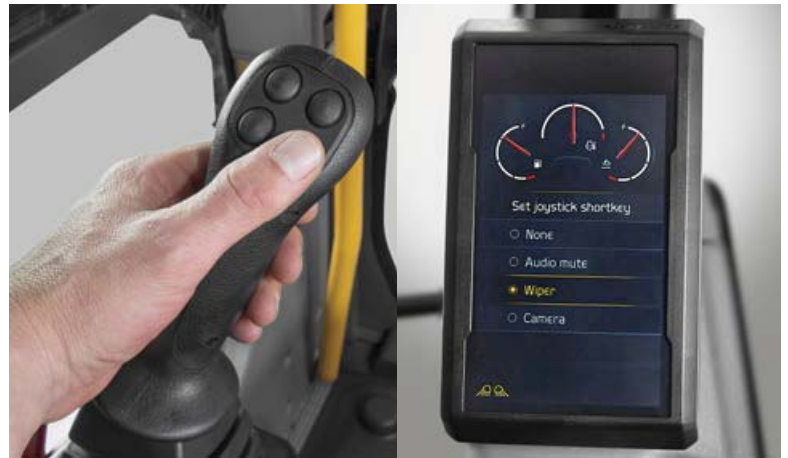

Bluetooth®

To aid operator convenience and support better productivity, you can now connect a Bluetooth device to the machine enabling hands free operation.



Climate control system

With more than 98% efficiency, Volvo's air filtration system provides the cleanest operator environment in the industry – even in dusty conditions. The high-capacity heating and ventilation system improves comfort, enhancing productivity..

From Strong to Stronger.

The EC160E not only encompasses state-of-the-art design but Volvo also recognizes that for technology to be truly innovative, top priorities need to be durability, quality and reliability for every function. This is why care has been taken to ensure every aspect of the machine is built to last while operating at the highest level of productivity.

ROPS

Volvo cabs are ROPS certified according to the rigorous ISO standards. Their reinforced steel structures ensure the operator is protected in the unlikely event of the machine rolling over..



Boom and Arm

The robust design includes internal plates positioned to support pressure points during the range of applications. This helps disperse the stress from high-pressure areas of the boom and arm, to ensure maximum productivity time after time, during the most demanding applications.



Lower frame

The intelligently designed X-shape lower frame enables even weight distribution increasing stability and durability - preventing damage from rock and debris.



Undercarriage

The idlers, track links, upper and bottom rollers are built to withstand all elements and terrain, to create improved long-lasting durability and support maximum uptime.



Built to last

Working in tough conditions means every component matters - this is why Volvo pays extra attention to each detail during the manufacturing process. Silicone caulking is used to prevent rust, waterproof harnesses and connections are installed - as well as heavy-duty door hinges and bolted-on protection for the work lights.



Ultimate tool carrier



The Volvo excavator can be outfitted with a wide variety of auxiliary circuits from the factory, from breaker and shear piping (X1) to rotator piping (X3). State of the art hydraulics provide the correct flow and pressure for special attachments such as mowers and grinders, shears, crushers and tilt rotators among other attachments. You can choose between the one or two pump flow to maximize profits and productivity..

Fits with Variety.

Volvo has listened to customer needs and designed an excavator that is not only capable of doing a variety of applications but can do them all at an unrivaled consistent quality. Not only can the EC160E work with a large number of attachments, it can easily switch between them to maximize uptime and productivity.

Attachment Management System

The password protected management system allows storage for up to 20 different attachments. It pre-sets and permits hydraulic flow and pressure to be adjusted within the cab, which ensures the use of various attachments for increased versatility.

Extra piping

An additional piping solution is available on the breaker and shear piping (X1), accommodating the use of tilt/rotator attachments.



Electrical pedal

The electric pedal offers precise control to allow the operator to use a wider variety of attachments.

Response mode

The attachment response sensitivity can be adjusted using the keypad. This allows the operator to tailor machine response for maximum impact in different environments.

Ground Control.

Proactive maintenance is crucial to prolong machine life – this is why making inspections safe and easy is a priority. Volvo has grouped access points together and made them safer to reach to ensure regular checks to maximize machine uptime while reducing the chances of any surprises.

Grouped filters

Filters are well grouped and easily accessible from the ground level. This facilitates the speed and ease of servicing.



Single layer cooling system

The radiator, charged air cooler and hydraulic oil cooler are situated side-by-side on a single layer, to maximize efficiency, reduce blockages and aid cleaning. The system is easily accessed from ground level by simply opening the side door.

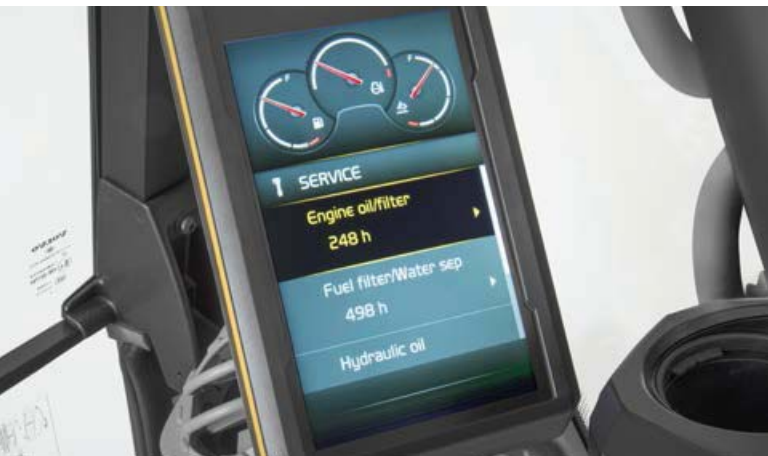

Service interval alerts

Real-time service alerts are displayed on the color monitor to enable diagnostic checks. Separate service intervals include – the engine oil filter, fuel filter, water separator, hydraulic oil and hydraulic oil filter. This ensures peace of mind and maximum uptime.



Anti-slip steel plates

Well-positioned punched anti-slip plates provide superior grip and durability. The design facilitates easy cleaning while ensuring safety.



Service access

Easy access for maintenance means regular checks are completed faster – increasing uptime and driving down total cost of ownership. The E-series features safe access guardrails to assist in checking the hydraulic tank, fuel tank and Diesel Exhaust Fluid (DEF). This is in addition to the easily accessible side entry, through a wide compartment door.



Matched attachments

Volvo's durable attachments have been purpose-built to work in perfect harmony with Volvo machines, forming one solid, reliable unit. With functions and properties ideally matched, Volvo attachments are an integrated part of the excavator for which they're intended.

Mix and match for a superior fit.

Maximize your productivity and profitability with Volvo's EC160E crawler excavator and a range of durable attachments. Increase your versatility, access more applications and perform a variety of tasks – all while experiencing faster cycle times and excellent control.

Buckets – GP/HD/XD

Volvo's buckets are the perfect tool for digging and re-handling in all conditions from soft, medium and hard materials. Heavy-duty buckets are intended for productive digging in compact materials. All provide maximum productivity and long life and feature the Volvo Tooth System..



Breakers

The HB-Series of hydraulic breakers are optimized to the specific weights of Volvo machines and tailored to Volvo quick couplers for swift, safe and simple attachment changes. They are available with a full assortment of tools.



S-type Coupler

The Volvo S-type quick coupler is designed to work with Volvo attachments - delivering ultimate compatibility and unrivalled performance.

Genuine Volvo wear parts

Volvo offers a selection of economic, replaceable wear parts including high quality teeth, segments, side cutters, adapters and shrouds to protect the bucket and ensure long life.



Universal Quick Coupler

The Volvo universal quick coupler offer maximum versatility. It picks up a variety of attachments from various manufacturers and meets new safety regulations.

Improved total cost of ownership.

Boom and arm

To achieve the best performance, select the most suitable boom and arm configuration combination for your requirements.



Ultimate tool carrier

Designed to not only be compatible with a range of attachments, but also to enhance their performance by easily and quickly switching to accommodate any needs.



Optimized hydraulics

Designed to perfectly match the engine power, reduce power loss, and improve controllability and response time.

Diesel Exhaust Fluid (DEF)

Volvo offers a total DEF solution that is quality assured, cost efficient and easily accessible. Contact your Volvo dealer for more information.

Boom float

The pump flow for boom lowering can be saved or used for other functions, reducing the cycle time. Also, the grading operation can be made easier.

Attachment management system

The password protected management system allows storage for up to 20 different attachments. It pre-sets and permits hydraulic flow and pressure to be adjusted within the cab.



Side view camera

Covers the visual blind spot at the side of machine. View is displayed on the color monitor, creating a safer working environment, protecting the operator and personnel on the ground.

Short cut key function

For ease of use, functions such as windshield wipers, cameras, auto-mute or power max function can all be assigned a short-cut button on the joystick



HMI

All machine interfaces are ergonomically positioned and designed for optimum control and efficiency.

Bluetooth®

Bluetooth and hands-free functions have been added, allowing the operator to connect to wireless functions for increased comfort and safety.



Service access

The E-series features a new convenient and safe access - such as guardrails - to check the hydraulic tank, fuel tank and Diesel Exhaust Fluid. This is in addition to the easily accessible side entry, through a wide compartment door.

Volvo engine

Volvo's D4 Tier 4 Final IV engine boasts more power while reducing both fuel consumption and emissions; delivering superior quality, reliability and durability.

Grouped filters

Filters are well grouped and easily accessible from the ground level. This facilitates the speed and ease of servicing.



Built to last

Volvo pays attention to the details. Silicone caulking is used to prevent rust, waterproof harnesses and connections have been installed - as well as heavy-duty door hinges and bolted-on protection for the framework lights.



Adding value to your business.

Being a Volvo customer means having a complete set of services at your fingertips. Volvo can offer you a long-term partnership, protect your revenue and provide a full range of customer solutions using high quality parts, delivered by passionate people. Volvo is committed to the positive return of your investment.



Complete Solutions

Volvo has the right solution for you. So why not let us provide all your needs throughout the whole life cycle of your machine? By listening to your requirements, we can reduce your total cost of ownership and increase your revenue.



Genuine Volvo Parts

Our attention to detail is what makes us stand out. This proven concept acts as a solid investment in your machine's future. Parts are extensively tested and approved because every part is vital for uptime and performance. Only by using Genuine Volvo Parts, can you be sure that your machine retains the renowned Volvo quality.



Service Network

In order to respond to your needs faster, a Volvo expert is on their way to your job site from one of our Volvo facilities. With our extensive infrastructure of technicians, workshops and dealers, Volvo has a comprehensive network to fully support you using local knowledge and global experience.



PROFITABILITY



SERVICE PLAN

	DAY01	DAY02	DAY03	DAY04	DAY05	DAY06	DAY07
✓							
						✓	
				✓	✓		
	✓						
						✓	✓
		✓					
✓							
			✓				
							✓

FUEL CONSUMPTION



Customer Support Agreements



The range of Customer Support Agreements offer preventive maintenance, total repairs and a number of uptime services. Volvo uses the latest technology to monitor machine operation and status, giving you advice to increase your profitability. By having a Customer Support Agreement you are in control of your service costs.

Volvo EC160E in detail.

Engine

The latest generation of Volvo Tier 4 Final diesel engines fully meets the demands of the latest, emissions regulations. Featuring Volvo Advanced Combustion Technology (V-ACT), it is designed to deliver superior performance and fuel efficiency. The engine uses precise, high pressure fuel injectors, turbo charger and air-to-air intercooler, and electronic engine controls to optimize machine performance. The Automatic Idling System reduces engine speed to idle when the levers and pedals are not activated resulting in less fuel consumption and low cab noise levels.

Engine	Volvo	D4J		
Max power at	r/min	2,000		
Net, ISO 9249/SAE J1349	kW	hp	109	146
Gross, ISO 14396/SAE J1995	kW	hp	110	148
Max power	Nm	lbf ft	609	449
at engine speed	r/min	1,600		
No. of cylinders	4			
Displacement	l	in ³	4.04	247
Bore	mm	in	101	3.98
Stroke	mm	in	126	4.96

Electrical system

Well protected high-capacity electrical system. Waterproof double-lock harness plugs are used to secure corrosion-free connections. The main relays and solenoid valves are shielded to prevent damage. The master switch is standard. Contronics provides advanced monitoring of machine functions and important diagnostic information.

Voltage	V	24		
Batteries	V	2 x 12		
Battery capacity	Ah	100		
Alternator	V / Ah	28 / 80		

Service refill capacities

Fuel tank	l	gal	250	66
Hydraulic system, total	l	gal	255	67
Hydraulic tank	l	gal	110	29
DEF tank	l	gal	20	5
Engine oil	l	gal	16	4
Engine coolant	l	gal	27	7
Swing reduction unit	l	gal	2.6	0.7
Travel reduction unit	l	gal	2 x 5.8	2 x 2

Swing system

The swing system uses an axial piston motors, driving a planetary gearbox for maximum torque. An automatic holding brake and anti-rebound valve are standard.

Max. slew speed	r/min	12.5		
Max. slew torque	kNm	lbf ft	51.7	38,130

Drive

Each track is powered by an automatic two-speed shift travel motor. The track brakes are multi-disc, spring-applied and hydraulic released. The travel motor, brake and planetary gears are well protected within the track frame.

Max. drawbar pull	kN	lbf	152	34,180
Max. travel speed	km/h	mph	3.1 / 5.6	1.9 / 3.5
Gradeability				°
				35

Undercarriage

Robust X-shaped frame with greased and sealed track chains as standard.

Track shoe				2 x 44
Link pitch	mm	in	190	7.5
			500	20
			600	24
Shoe width, triple grouser	mm	in	700	28
			800	32
			900	36

Bottom rollers				2 x 7
Top rollers				2 x 2

Hydraulic system

The hydraulics system, combined with the fully electronic control system and advanced ECO mode, has been optimized to work in harmony with engine to match the engine power, reduce power loss and improve controllability and response time.

The following important functions are included in the system:

Summation system: Combines the flow of both hydraulic pumps to ensure quick cycle times and high productivity.

Arm priority: Gives priority to the arm operation for faster cycle times in leveling and for increased bucket filling when digging.

Swing priority: Gives priority to swing functions for faster simultaneous operations.

Regeneration system: Prevents cavitation and provides flow to other movements during simultaneous operations for maximum productivity.

Power boost: All digging and lifting forces are increased.

Holding valves: Boom and arm holding valves prevent the digging equipment from creeping.

Main pump

Type	2 x variable displacement axial piston pumps			
Maximum flow	l/min	gpm	2 x 152	2 x 40

Pilot pump

Type	Gear pump			
Maximum flow	l/min	gpm	1 x 20	1 x 5

Relief valve setting

Implement	MPa	psi		
Standard	MPa	psi	34.3	4,980
Power Boost	MPa	psi	36.3	5,260
Travel circuit	MPa	psi	34.3	4,980
Slew circuit	MPa	psi	26.5	3,840
Pilot circuit	MPa	psi	3.9	570

Hydraulic motors

Travel: Variable displacement axial piston motor with mechanical brake

Slew: Fixed displacement axial piston motor with mechanical brake

Hydraulic cylinders

Mono boom			2
Bore x Stroke	ø x mm	115 x 1	165
	ø x in	4.5 x	45.9
Arm			1
Bore x Stroke	ø x mm	120 x 1	345
	ø x in	4.7 x	53.0
Bucket			1
Bore x Stroke	ø x mm	105 x 1	000
	ø x in	4.1 x	39.4
Dozer blade			2
Bore x Stroke	ø x mm	140 x	320
	ø x in	5.5 x	12.6

Cab

The operator's cab has easy access via a wide door opening. The cab is supported on hydraulic dampening mounts to reduce shock and vibration levels. These along with a sound absorbing lining provide low noise levels. The cab has excellent all-round visibility. The front windshield can easily slide up into the ceiling, and the lower front glass can be removed and stored in the side door.

Integrated air-conditioning and heating system: The pressurized and filtered cab air is supplied by an automatically-controlled fan. The air is distributed throughout the cab from 14 vents.

Ergonomic operator's seat: The adjustable seat and joystick console move independently to accommodate the operator. The seat has nine different adjustments plus a seat belt for the operator's comfort and safety.

Sound Level

Sound level in cab according to ISO 6396

LpA (standard)	dB(A)	69
LpA (tropical)	dB(A)	70
External sound level according to ISO 6395, EU Noise Directive (2000/14/EC)		
LwA (standard)	dB(A)	101
LwA (tropical)	dB(A)	102

Specifications.

DIMENSIONS

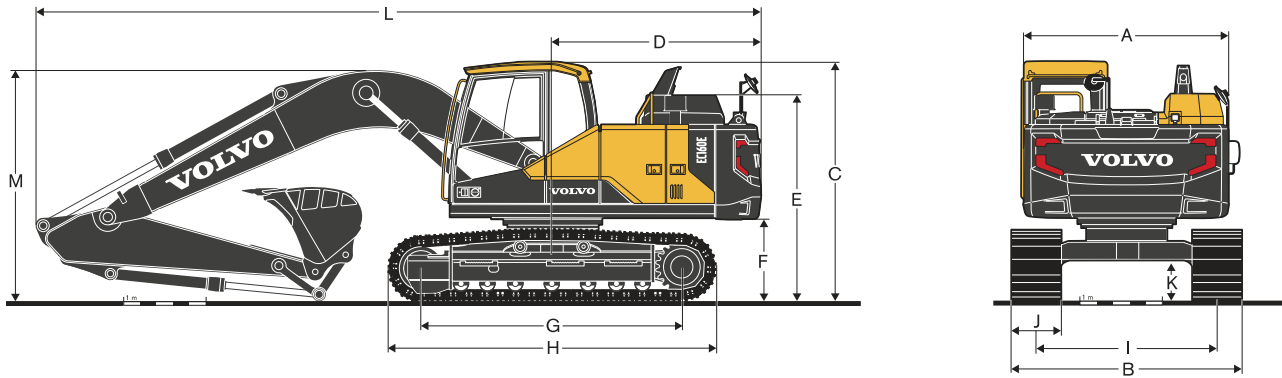

Description	Unit		EC160EL					
	m, ft in		5.2, 17' 1"					
Arm	m	ft in	2.3	7' 7"	2.6	8' 6"	3.0	9' 10"
A Overall width of upper structure	mm	ft in	2 490	8' 2"	2 490	8' 2"	2 490	8' 2"
B Overall width	mm	ft in	2 590	8' 6"	2 590	8' 6"	2 590	8' 6"
C Overall height of cab	mm	ft in	2 900	9' 6"	2 900	9' 6"	2 900	9' 6"
D Tail swing radius	mm	ft in	2 550	8' 4"	2 550	8' 4"	2 550	8' 4"
E Overall height of engine hood	mm	ft in	2 510	8' 3"	2 510	8' 3"	2 510	8' 3"
F Counterweight clearance*	mm	ft in	1 010	3' 4"	1 010	3' 4"	1 010	3' 4"
G Tumbler length	mm	ft in	3 180	10' 5"	3 180	10' 5"	3 180	10' 5"
H Track length	mm	ft in	3 980	13' 1"	3 980	13' 1"	3 980	13' 1"
I Track gauge	mm	ft in	1 990	6' 6"	1 990	6' 6"	1 990	6' 6"
J Shoe width	mm	ft in	600	2' 0"	600	2' 0"	600	2' 0"
K Min. ground clearance*	mm	ft in	460	1' 6"	460	1' 6"	460	1' 6"
L Overall length	mm	ft in	8 880	29' 2"	8 770	28' 9"	8 810	28' 11"
M Overall height of boom	mm	ft in	2 980	9' 9"	2 900	9' 6"	3 020	9' 11"

* Without shoe grouser

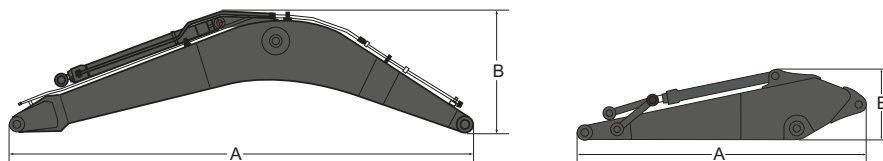

Description	Unit		mono		Description	Unit		EC160EL					
	m	ft in	5.2	17' 1"		m	ft in	2.3	7' 7"	2.6	8' 6"	3.0	9' 10"
A Length	mm	ft in	5 400	17' 9"	A Length	mm	ft in	3 240	10' 8"	3 500	11' 6"	3 900	12' 10"
B Height	mm	ft in	1 640	5' 5"	B Height	mm	ft in	855	2' 10"	855	2' 10"	845	2' 9"
Width	mm	ft in	565	1' 10"	Width	mm	ft in	395	1' 4"	395	1' 4"	395	1' 4"
Weight	kg	lb	1 370	3,020	Weight	kg	lb	790	1,740	800	1,760	860	1,900

* Includes cylinder, piping and pin, excludes boom cylinder pin * Includes cylinder, linkage and pin

Front dozer blade		Unit	
A Height	mm	ft in	452 1' 6"
Width	mm	ft in	2 590 8' 6"
Weight	kg	lb	553 1,220
B Lift height	mm	ft in	571 1' 10"
C Digging depth	mm	ft in	735 2' 5"

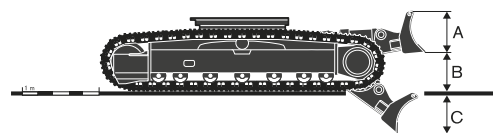

WORKING RANGES

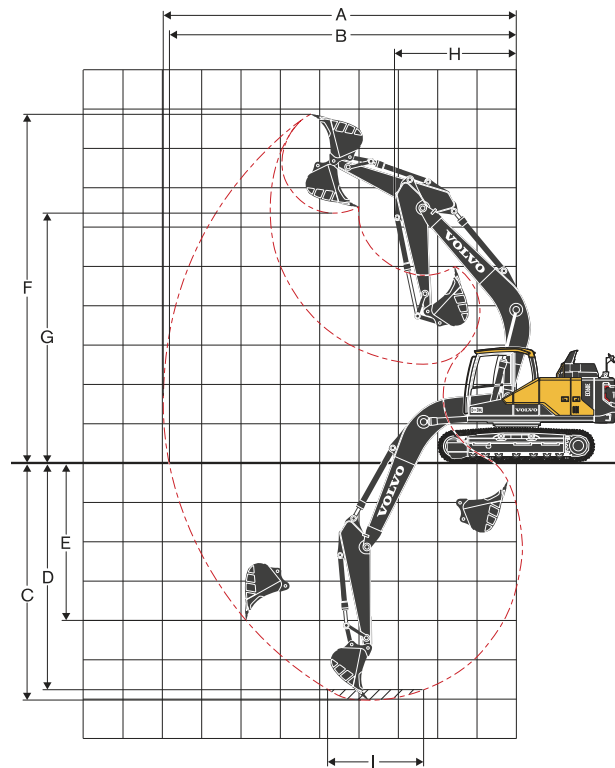

Description		Unit		EC160EL					
		m, ft in		5.2, 17' 1" mono					
Boom									
Arm		m	ft in	2.3	7' 7"	2.6	8' 6"	3.0	9' 10"
A	Max. digging reach	mm	ft in	8 660	28' 5"	8 980	29' 6"	9 350	30' 8"
B	Max. digging reach on ground	mm	ft in	8 500	27' 11"	8 820	28' 11"	9 200	30' 2"
C	Max. digging depth	mm	ft in	5 770	18' 11"	6 070	19' 11"	6 470	21' 3"
D	Max. digging depth (2.44 m / 8' level)	mm	ft in	5 470	17' 11"	5 810	19' 1"	6 240	20' 6"
E	Max. vertical wall digging depth	mm	ft in	4 510	14' 10"	4 990	16' 4"	5 410	17' 9"
F	Max. cutting height	mm	ft in	8 560	28' 1"	8 820	28' 11"	9 030	29' 8"
G	Max. dumping height	mm	ft in	6 080	19' 11"	6 310	20' 8"	6 510	21' 4"
H	Min. front swing radius	mm	ft in	3 070	10' 1"	3 070	10' 1"	3 070	10' 1"

DIGGING FORCES WITH DIRECT FIT BUCKET

Bucket radius			mm	ft in	1 319	4' 4"	1 319	4' 4"	1 319	4' 4"
Breakout force - bucket	Normal	SAE J1179	kN	lbf	101.5	22,810	101.5	22,810	101.5	22,820
	Power boost	SAE J1179	kN	lbf	107.3	24,110	107.3	24,120	107.3	24,130
	Normal	ISO 6015	kN	lbf	115.3	25,910	115.3	25,920	115.3	25,930
Tearout force - dipper arm	Power boost	ISO 6015	kN	lbf	121.9	27,390	121.9	27,400	121.9	27,410
	Normal	SAE J1179	kN	lbf	90.0	20,230	80.0	17,980	72.5	16,290
	Power boost	SAE J1179	kN	lbf	95.1	21,390	84.6	19,010	76.6	17,220
	Normal	ISO 6015	kN	lbf	92.2	20,730	81.7	18,370	73.8	16,600
Power boost	ISO 6015	kN	lbf	97.5	21,910	86.4	19,420	78.1	17,550	
Rotation angle, bucket			°		183		183		183	

Specifications.

MACHINE WEIGHTS AND GROUND PRESSURE

EC160EL		5.2 m / 17' 1" boom, 2.6 m / 8' 6" arm, 514 kg / 1,130 lb - 0.7 m ³ / 0.93 yd ³ bucket, 3 200 kg / 7,060 lb counterweight						
Description	Shoe width		Operating weight		Ground pressure		Overall width	
	mm	in	kg	lb	kPa	psi	mm	in
Without dozer blade								
Triple grouser	500	20	17 640	38,890	50.0	7.3	2 490	8' 2"
	600	24	17 870	39,390	42.2	6.1	2 590	8' 6"
	700	28	18 100	39,910	36.3	5.3	2 690	8' 10"
	800	32	18 500	40,790	32.4	4.7	2 790	9' 2"
	900	36	18 760	41,370	29.4	4.3	2 990	9' 10"
With dozer blade								
Triple grouser	500	20	18 810	41,480	53.0	7.7	2 490	8' 2"
	600	24	19 040	41,990	45.1	6.5	2 590	8' 6"
	700	28	19 280	42,510	39.2	5.7	2 690	8' 10"
	800	32	19 675	43,380	35.3	5.1	2 790	9' 2"
	900	36	19 940	43,970	31.4	4.6	2 990	9' 10"

BUCKET SELECTION GUIDE

Bucket type		Capacity		Cutting width		Weight		Teeth	EC160EL			EC160EL with dozer blade		
									5.2 m / 17' 1" boom, 600 mm / 24" shoe, 3 200 kg / 7,060 lb counterweight					
		m ³	yd ³	mm	ft	kg	lb	EA	2.3 m / 7' 7" arm	2.6 m / 8' 6" arm	3.0 m / 9' 10" arm	2.3 m / 7' 7" arm	2.6 m / 8' 6" arm	3.0 m / 9' 10" arm
Direct fit Buckets	General purpose	0.30	0.39	450	17.72	390	861	3	C	C	C	C	C	C
		0.36	0.47	600	23.62	417	919	3	C	C	C	C	C	C
		0.46	0.60	750	29.53	450	992	3	C	C	C	C	C	C
		0.58	0.76	900	35.43	505	1,114	4	C	C	C	C	C	C
		0.70	0.92	1050	41.34	550	1,213	4	C	C	C	C	C	C
	Heavy duty	0.84	1.10	1200	47.24	618	1,362	5	C	C	C	C	C	C
		0.30	0.39	450	17.72	382	841	3	D	D	D	D	D	D
		0.36	0.47	600	23.62	409	903	3	D	D	D	D	D	D
		0.46	0.60	750	29.53	444	979	3	D	D	D	D	D	D
		0.58	0.76	900	35.43	511	1,126	4	D	D	D	D	D	D

Please consult with your Volvo dealer for the proper match of buckets and attachments to suit the application.

The recommendations are given as a guide only, based on typical operation conditions.

Bucket capacity based on ISO 7451, heaped material with a 1:1 angle of repose.

Maximum material density

	kg/m ³	lb/yd ³	
A	1 200 - 1 300	2,000 - 2,200	Coal, Caliche, Shale
B	1 400 - 1 600	2,300 - 2,700	Wet earth and clay, Limestone, Sandstone
C	1 700 - 1 800	2,800 - 3,100	Granite, Wet sand, Well blasted rock
D	> 1 900	> 3,200	Wet mud, Iron ore

LIFTING CAPACITY EC160EL

Lifting capacity at the arm end without bucket.

For lifting capacity including bucket, simply subtract actual weight of the direct fit bucket or the bucket with quick coupler from the following values.

	Lifting hook related to ground level	1.5 m, 5 ft		3.0 m, 10 ft		4.5 m, 15 ft		6.0 m, 20 ft		7.5 m, 25 ft		Max. Reach			
		Along UC	Across UC	Along UC	Across UC	Along UC	Across UC	Along UC	Across UC	Along UC	Across UC	Along UC	Across UC		
Boom: 5.2 / 17' 1" Arm: 2.3 m / 7' 7" Shoe: 600 mm / 24' CWT: 3 200 kg / 7,060 lb	6.0 m kg	-	-	-	-	-	-	-	-	-	-	4 480	3 650	5.9 m	
	20 ft lb	-	-	-	-	-	-	-	-	-	-	*9,860	8,220	19.0 ft	
	4.5 m kg	-	-	-	-	*4 970	*4 970	*4 660	3 480	-	-	4 490	2 880	6.8 m	
	15 ft lb	-	-	-	-	*10,770	*10,770	10,230	7,500	-	-	9,990	6,400	22.1 ft	
	3.0 m kg	-	-	-	-	*6 580	5 050	5 290	3 340	-	-	3 990	2 530	7.2 m	
	10 ft lb	-	-	-	-	*14,180	10,920	11,400	7,220	-	-	8,810	5,610	23.6 ft	
	1.5 m kg	-	-	-	-	7 920	4 730	5 130	3 200	-	-	3 820	2 410	7.3 m	
	5 ft lb	-	-	-	-	17,060	10,230	11,050	6,910	-	-	8,420	5,310	24.1 ft	
	0 m kg	-	-	-	-	7 720	4 560	5 010	3 100	-	-	3 920	2 450	7.1 m	
	0 ft lb	-	-	-	-	16,610	9,850	10,800	6,690	-	-	8,640	5,410	23.4 ft	
	-1.5 m kg	-	-	-	-	10 820	8 360	7 670	4 970	3 060	-	-	4 360	2 710	6.6 m
	-5 ft lb	-	*24,720	17,960	16,500	9,750	10,730	6,620	-	-	-	-	9,650	6,000	21.6 ft
	-3.0 m kg	-	-	*13 000	8 500	7 750	4 590	-	-	-	-	-	5 590	3 430	5.6 m
	-10 ft lb	-	*28,150	18,280	16,670	9,900	-	-	-	-	-	-	12,470	7,650	18.2 ft
	Boom: 5.2 / 17' 1" Arm: 2.6 m / 8' 6" Shoe: 600 mm / 24' CWT: 3 200 kg / 7,060 lb	7.5 m kg	-	-	-	-	-	-	-	-	-	-	*4 110	*4 110	4.8 m
25 ft lb		-	-	-	-	-	-	-	-	-	-	*9,050	*9,050	15.4 ft	
6.0 m kg		-	-	-	-	-	-	-	*4 150	3 570	-	-	*3 760	3 320	6.3 m
20 ft lb		-	-	-	-	-	-	-	*9,030	7,680	-	-	*8,320	7,460	20.3 ft
4.5 m kg		-	-	-	-	*4 570	*4 570	*4 390	3 510	-	-	*3 680	2 680	7.1 m	
15 ft lb		-	-	-	-	*9,930	*9,930	*9,630	7,570	-	-	*8,130	5,960	23.2 ft	
3.0 m kg		-	-	*9 730	9 330	*6 190	5 120	*5 090	3 370	3 770	2 400	3 750	2 380	7.5 m	
10 ft lb		-	-	*20,590	20,160	*13,350	11,060	*11,080	7,280	-	-	8,280	5,280	24.7 ft	
1.5 m kg		-	-	-	-	*7 930	4 780	5 150	3 220	3 700	2 340	3 600	2 270	7.7 m	
5 ft lb		-	-	-	-	*17,130	10,320	11,090	6,940	7,980	5,040	7,930	5,010	25.1 ft	
0 m kg		-	-	*5 620	*5 620	7 740	4 570	5 020	3 100	-	-	3 680	2 300	7.5 m	
0 ft lb		-	-	*13,000	*13,000	16,640	9,870	10,820	6,690	-	-	8,110	5,090	24.5 ft	
-1.5 m kg		*5 790	*5 790	*9 910	8 310	7 660	4 510	4 960	3 050	-	-	4 050	2 520	6.9 m	
-5 ft lb		*12,980	*12,980	*22,600	17,860	16,470	9,730	10,700	6,590	-	-	8,950	5,580	22.7 ft	
-3.0 m kg		*10 330	*10 330	*13 460	8 440	7 710	4 550	-	-	-	-	5 020	3 100	6.0 m	
-10 ft lb	*23,240	*23,240	*29,140	18,140	16,590	9,830	-	-	-	-	11,180	6,900	19.5 ft		
-4.5 m kg	-	-	*10 810	8 720	-	-	-	-	-	-	*7 450	4 980	4.4 m		
-15 ft lb	-	-	*23,080	18,790	-	-	-	-	-	-	*16,540	11,410	13.9 ft		
Boom: 5.2 / 17' 1" Arm: 3.0 m / 9' 10" Shoe: 600 mm / 24' CWT: 3 200 kg / 7,060 lb	7.5 m kg	-	-	-	-	-	-	-	-	-	-	*3 470	*3 470	5.4 m	
	25 ft lb	-	-	-	-	-	-	-	-	-	-	*7,760	*7,760	17.3 ft	
	6.0 m kg	-	-	-	-	-	-	-	*3 660	3 610	-	-	*3 170	2 980	6.7 m
	20 ft lb	-	-	-	-	-	-	-	*8,160	7,750	-	-	*7,010	6,680	21.8 ft
	4.5 m kg	-	-	-	-	-	-	-	*3 990	3 530	-	-	*3 110	2 450	7.5 m
	15 ft lb	-	-	-	-	-	-	-	*8,740	7,600	-	-	*6,850	5,450	24.5 ft
	3.0 m kg	-	-	*8 200	*8 200	*5 610	5 160	*4 720	3 370	3 770	2 390	*3 200	2 190	7.9 m	
	10 ft lb	-	-	*17,400	*17,400	*12,100	11,150	*10,290	7,280	8,110	5,150	*7,050	4,850	25.9 ft	
	1.5 m kg	-	-	*5 660	*5 660	*7 430	4 790	5 140	3 200	3 680	2 310	3 330	2 090	8.0 m	
	5 ft lb	-	-	*13,630	*13,630	*16,040	10,350	11,070	6,910	7,940	4,990	7,340	4,610	26.3 ft	
	0 m kg	-	-	*6 130	*6 130	7 720	4 550	4 990	3 070	3 610	2 250	3 390	2 110	7.8 m	
	0 ft lb	-	-	*14,100	*14,100	16,590	9,810	10,750	6,620	7,790	4,850	7,480	4,660	25.7 ft	
	-1.5 m kg	*5 290	*5 290	*9 280	8 190	7 600	4 450	4 910	3 000	-	-	3 690	2 290	7.3 m	
	-5 ft lb	*11,850	*11,850	*21,140	17,600	16,330	9,590	10,580	6,470	-	-	8,160	5,060	24.1 ft	
	-3.0 m kg	*8 980	*8 980	*13 880	8 290	7 620	4 460	4 920	3 010	-	-	4 440	2 740	6.5 m	
-10 ft lb	*20,200	*20,200	*30,040	17,810	16,380	9,630	10,630	6,510	-	-	9,870	6,090	21.1 ft		
-4.5 m kg	-	-	*11 770	8 530	7 790	4 610	-	-	-	-	6 650	4 010	5.0 m		
-15 ft lb	-	-	*25,240	18,360	16,780	9,970	-	-	-	-	15,120	9,100	16.0 ft		

Notes: 1. Machine in "Fine Mode-F" (Power Boost) for lifting capacities. 2. The above loads are in compliance with SAE J1097 and ISO 10567 Hydraulic Excavator Lifting Capacity Standards. 3. Rated loads do not exceed 87% of hydraulic lifting capacity or 75% of tipping load. 4. Rated loads marked with an asterisk (*) are limited by hydraulic capacity rather than tipping load.

Equipment.

STANDARD EQUIPMENT

Engine

Turbocharged, 4 stroke diesel engine with water cooling, direct injection and charged air cooler that meets Tier 4f EU (Stage IV) requirements
 Air filter with indicator
 Air intake heater
 Cyclone pre-cleaner
 Electric engine shut-off
 Fuel filter and water separator
 Tropical cooling system
 Alternator, 80 A

Electric/Electronic control system

Contronics
 Advanced mode control system
 Self-diagnostic system
 Machine status indication
 Satellite Caretrack and Caretrack subscription
 Engine speed sensing power control
 Automatic idling system
 One-touch power boost
 Safety stop/start function
 Adjustable LCD color monitor
 Master electrical disconnect switch
 Engine restart prevention circuit
 Travel alarm
 High-capacity halogen lights:
 Frame-mounted: 2, Boom-mounted: 1
 Batteries, 2 x 12 V / 100 Ah
 Start motor, 24 V / 5.5 kW

Hydraulic system

Boom float function without HRV
 Automatic sensing hydraulic system
 Summation system
 Boom priority
 Arm priority
 Swing priority
 ECO mode fuel saving technology
 Boom, arm and bucket regeneration valves
 Swing anti-rebound valves
 Boom and arm holding valves
 Multi-stage filtering system
 Boom cylinders (x2)
 Cylinder cushioning
 Cylinder contamination seals
 Auxiliary hydraulic valve
 Automatic two-speed travel motors
 Pilot control pattern change
 Hydraulic oil, ISO oil 46

Frame

Access way with handrail
 Tool storage area
 Punched metal anti-slip plates
 Heavy duty lower cover plates
 3 200 kg, 7,060 lb counterweight

Cab and interior

ROPS (ISO12117-2) certified cab with openable roof hatch
 Silicon oil and rubber mounts with spring
 Control lock out lever
 Travel pedals and hand levers
 Straight travel pedal
 Adjustable operator seat with heater
 Control joysticks with 4 switches each
 Heater & air-conditioner, automatic
 Flexible antenna
 Radio with AUX, USB Jack and Bluetooth
 Cab, all-weather sound suppressed, includes:
 Cup holders
 Door locks
 Tinted glass
 Floor mat
 Horn
 Large storage area
 Pull-up type front window
 Removable lower windshield
 Seat belt
 Safety glass
 Sun screens, front, roof, rear
 Windshield wiper with intermittent feature
 Rear view camera
 Master key

Undercarriage

Heavy Duty belly cover plates
 Hydraulic track adjusters
 Greased and sealed track link
 Track Guard

Digging equipment

5.2 m / 17' 1" mono boom
 2.6 m / 8' 6" arm
 Reinforced linkage
 Manual centralized lubrication

OPTIONAL EQUIPMENT

Engine

Block heater: 120 V
 Diesel coolant heater, 5 kW
 Water separator with heater
 Auto engine shutdown
 Standard cooling system
 Fuel filler pump: 35 l/min / 9 gpm

Electric

High-capacity LED lights:
 Frame-mounted: 2, Boom-mounted: 1
 Extra work lights (Halogen or LED):
 Boom-mounted 1
 Cab-mounted 3
 Counterweight-mounted 1
 Anti-theft system
 Rotating warning beacon

OPTIONAL EQUIPMENT

Hydraulic system

Boom hose rupture valve with overload warning device

Arm hose rupture valve

Boom float function with HRV

Hydraulic piping:

Work tool management system (up to 20 programmable memorized settings)

Breaker & shear, 1 or 2 pump flow

Slope & rotator (40 lpm, 11 gpm or 60 lpm, 16 gpm)

Extra for slope & rotator

Grapple

Oil leak (drain) line

Quick coupler

Additional return filter

Breaker & shear pressure pre-setting

Volvo hydraulic quick coupler S1, S6

Volvo hydraulic quick coupler VQC-HU,DR16

Hydraulic oil, biodegradable 46

Hydraulic oil, longlife oil 32, 68

Cab and interior

ROPS (ISO12117-2) certified cab with fixed hatch

Fabric seat without heater

Fabric seat with heater and air suspension

Control joysticks with semi-long

Control joysticks with 3 switch & 1 proportional

Cab-mounted falling object guard (FOG)

Cab-mounted falling object protective structure (FOPS)

Anti-vandalism kit

Safety net for front window

Side view camera

Smoker kit (ashtray and lighter)

Sunlight protection, roof (steel)

Lower wiper with intermittent control

Rain shield

Specific key

Undercarriage

Dozer blade

500 mm, 20"/600 mm, 24"/700 mm, 28"/800 mm, 32"/900 mm, 36" shoe with triple grousers

Digging equipment

2.3 m/7' 7" , 3.0 m/9' 10" arm

Linkage with lifting eye

Service

Tool kit, daily maintenance

Tool kit, full scale

Selection of Volvo optional equipment

Auto engine shutdown



Two-piece boom



Diesel coolant heater

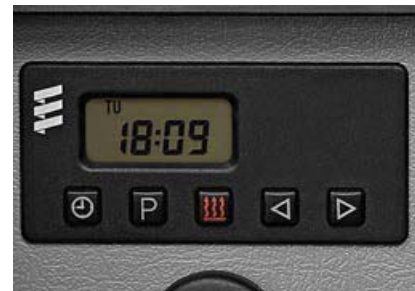

LED lights



Fuel filler pump



Falling Objects Guard (FOG)



Not all products are available in all markets. Under our policy of continuous improvement, we reserve the right to change specifications and design without prior notice. The illustrations do not necessarily show the standard version of the machine.

VOLVO

Volvo Construction Equipment

www.volvoce.com