



Volvo Construction Equipment

# L110H, L120H

VOLVO WHEEL LOADERS 18.0-21.6t / 39,683-47,620lbs 259-276hp



# A passion for performance

At Volvo Construction Equipment, we're not just coming along for the ride. Developing products and services that raise productivity – we are confident we can lower costs and increase profits for customers around the globe. Part of the Volvo Group, we are passionate about innovative solutions to help you work smarter – not harder.

## Helping you to do more

Doing more with less is a trademark of Volvo Construction Equipment. High productivity has long been married to low energy consumption, ease of use and durability. When it comes to lowering life-cycle costs, Volvo is in a class of its own.

## Designed to fit your needs

There is a lot riding on creating solutions that are suited to the particular needs of different industry applications. Innovation often involves high technology – but it doesn't always have to. Some of our best ideas have been simple, based on a clear and deep understanding of our customers' working lives.



## You learn a lot in 180 years

Over the years, Volvo has advanced solutions that have revolutionized the use of construction equipment. No other name speaks Safety louder than Volvo. Protecting operators, those around them and minimizing our environmental impact are traditional values that continue to shape our product design philosophy.

## We're on your side

We back the Volvo brand with the best people. Volvo is truly a global enterprise, one that is on standby to support customers quickly and efficiently – wherever they are.

## We have a passion for performance.

### A strong, dedicated, capable dealer network.

Our dealers are strategically located throughout North America to provide the equipment you need and the parts and service support you demand for a productive and profitable operation.

The strength of our dealer network is enhanced with extensive individualized product support training at our best-in-class Customer Center in Shippensburg and through hands-on training. Using a great Product Demonstration Center featuring a dedicated area for most common applications, visitors operate equipment from our entire product line under a variety of simulated working conditions. This facility is in year-round use by our dealers and customers.

### Building the best starts right here.

The products designed and manufactured by Volvo Construction Equipment have their beginnings at the most advanced Research & Design centers in the industry. Volvo CE machines are designed in 11 R&D centers and produced in 15 manufacturing facilities across the world.

The major R&D center and manufacturing plant in the Americas is located in Shippensburg, Pennsylvania. This facility has been in operation for over 30 years and – with its recently added 200,000 sq. ft. expansion – now covers 570,000 sq. ft. on an 80 acre campus. Dedicated work teams and highly advanced technologies and techniques using the Volvo Production System ensure continuous quality improvements, labor savings and cost control to reach the high quality that our customers have come to expect from Volvo.





Volvo Trucks



Renault Trucks



Mack Trucks



UD Trucks



Volvo Buses



Volvo Construction Equipment



Volvo Penta



Volvo Financial Services

# Revolutionary fuel efficiency.

At Volvo we know that fuel efficiency is one of your highest priorities. That's why our engineers are constantly developing clever innovations to make equipment more fuel efficient. Our unique, award-winning OptiShift technology – which reduces fuel consumption by up to 18% and increases machine performance – is a prime example of this.

## Reverse By Braking (RBB)

The RBB function senses the loader's direction and slows the machine when the operator wants to change direction by reducing engine rpm and applying the service brakes automatically. This increases operator comfort and reduces stress on the drivetrain – extending component life.



## Eco pedal

Volvo's unique eco pedal applies mechanical push-back force when the accelerator is used excessively and engine rpm is about to exceed the economic operating range. This encourages the operator to ease off the throttle, reducing fuel consumption.



## Intelligent hydraulics

Volvo's load-sensing hydraulics supply power to the hydraulic functions according to demand, lowering fuel consumption. The powerful system ensures fast response for shorter cycle times while delivering smooth operation through superior control of both the load and attachment.

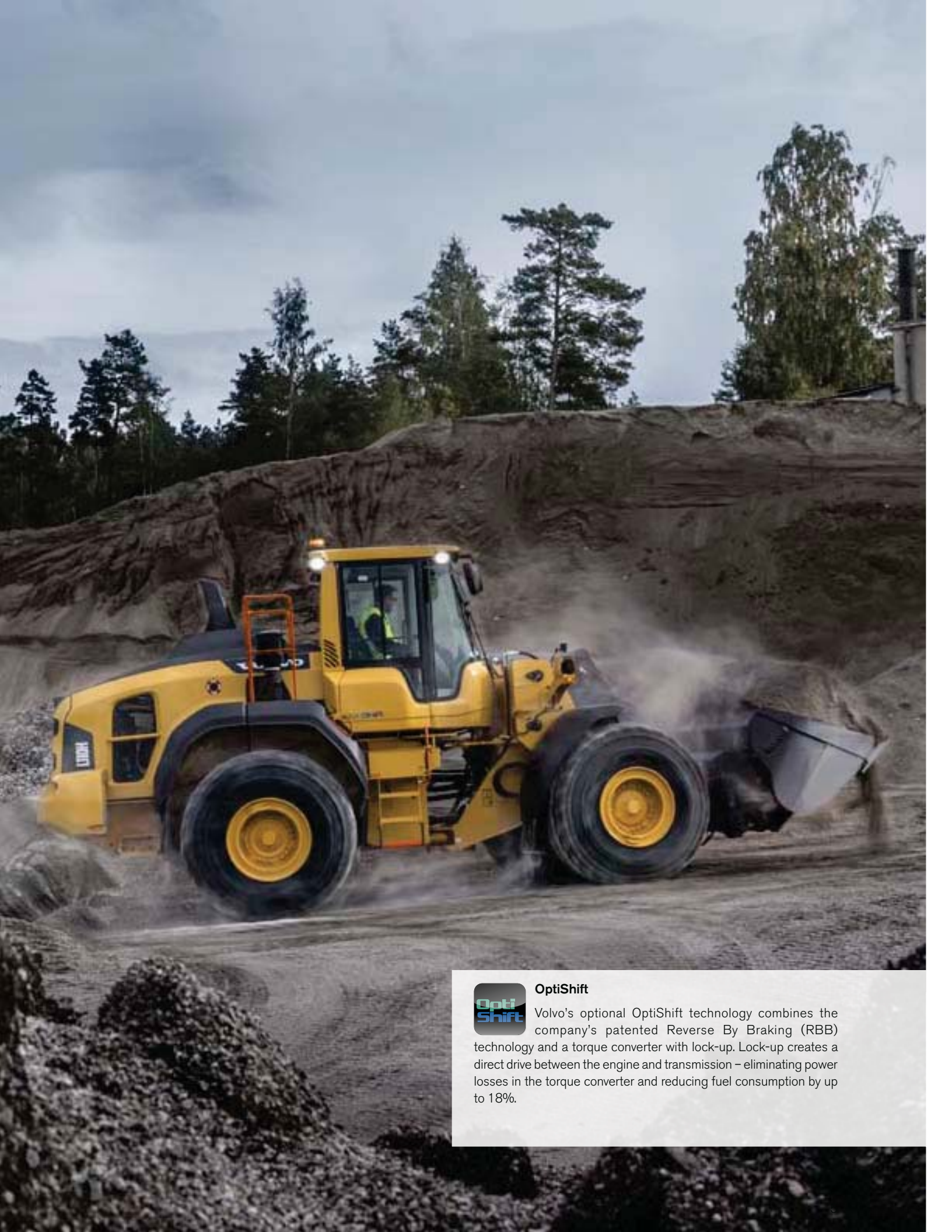

### OptiShift

Volvo's optional OptiShift technology combines the company's patented Reverse By Braking (RBB) technology and a torque converter with lock-up. Lock-up creates a direct drive between the engine and transmission – eliminating power losses in the torque converter and reducing fuel consumption by up to 18%.

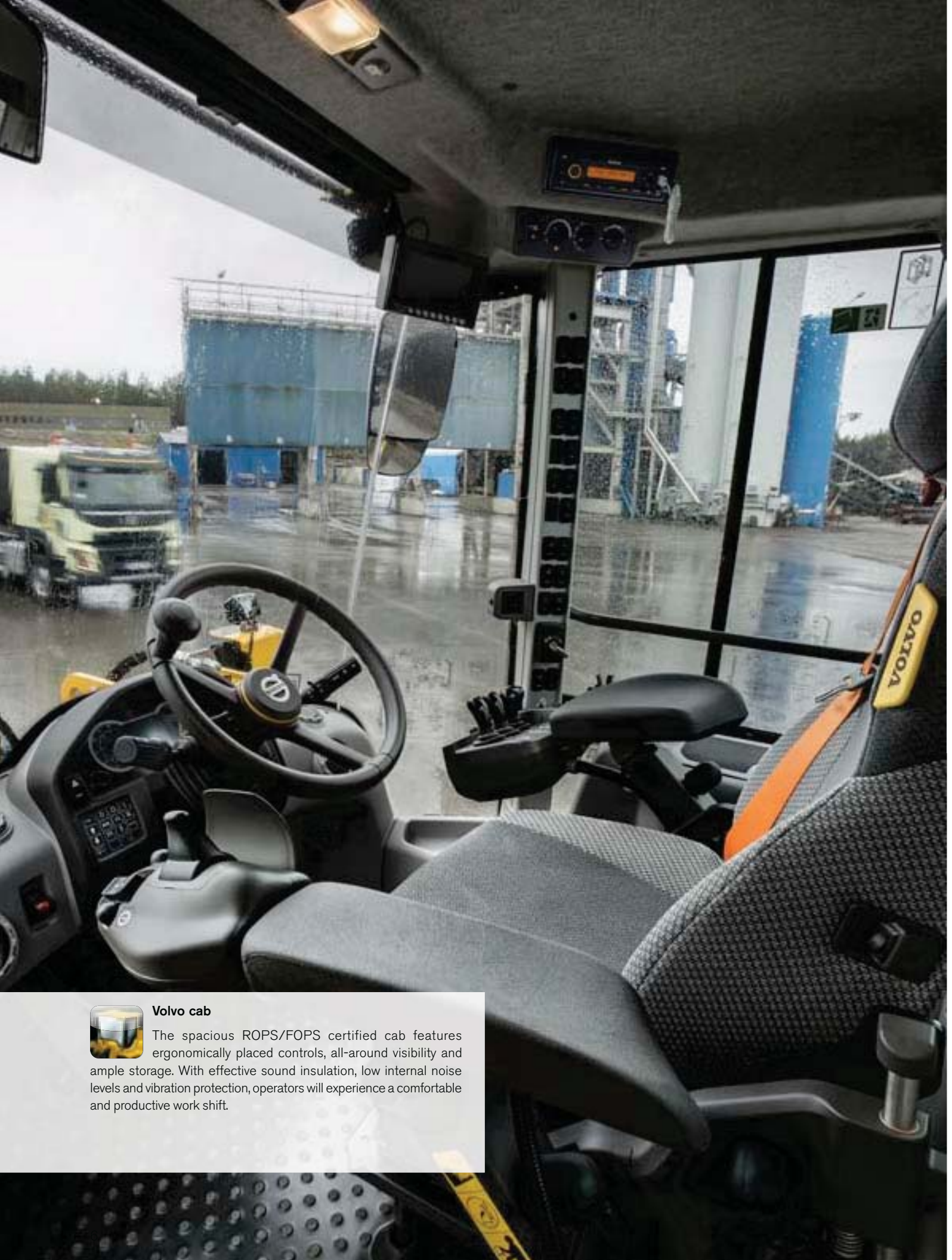

#### Volvo cab

The spacious ROPS/FOPS certified cab features ergonomically placed controls, all-around visibility and ample storage. With effective sound insulation, low internal noise levels and vibration protection, operators will experience a comfortable and productive work shift.

# Comfort unlocks productivity.

Volvo's industry-leading cab has been designed with the operator in focus – providing a spacious, safe and quiet environment that's perfect for optimizing productivity all day long. With all-around visibility and a comfortable seat, step inside and see the difference this premium working environment will make to your performance.

## Safe access

Easily and safely access the cab via a three-point access ladder with anti-slip steps. Ideally positioned, sturdy handrails and a wide door frame with a 95° opening angle further increase operator safety and comfort – as do the optional remote door opener and cab entrance light.



## Information panel

The display clearly presents the operator with vital machine information including fuel levels and warning messages – ensuring optimal operation. From the operator seat, basic configurations and tests can be performed via the panel – which is easy-to-read even in bright sunlight.



## Single lever control

For ease of operation, the optional, multi-functional joystick gives the operator simultaneous and precise control of the hydraulic functions. Forward, reverse and kick-down functions are also included on the console.



## Cab air filter

The cab air intake is located high on the machine, where air is cleanest. The easy-to-replace pre-filter effectively separates coarser dust and particles before the air passes through the main filter and finally enters the cab. Volvo's industry-leading design allows 90% of the cab air to be recirculated through the main filter for continuous dust removal.

# Powerful. Durable. Reliable.

Featuring a premium Volvo Tier 4 Final/Stage IV engine and perfectly matched drivetrain and hydraulics, the L110H and L120H wheel loaders deliver the power, productivity and reliability you expect from Volvo. Whether you're working in the quarrying, material handling, recycling or any other application, these durable machines won't let you down.

## Maintaining a smooth operation

Enjoy peace-of-mind for maximum machine uptime with the rear axle design. The sealed oscillation pins cradle keeps the grease in and the dirt out, keeping components greased for up to 8,000 hours so you can rely on reduced overall service time and costs.



## Reversible cooling fan

The hydraulically-driven, electronically controlled cooling fan regulates the temperature of the vital components. It automatically activates only when it's needed – reducing fuel consumption and noise. The reversible functionality – which blows air in the opposite direction – allows for self-cleaning of the cooling units.

## Volvo engine

Featuring advanced technology and built on decades of experience, the powerful, new Volvo engine meets the Tier 4 Final/Stage IV emission regulations and delivers the ultimate combination of high performance and low fuel consumption.





#### **Powertrain**

The ideally-matched, all-Volvo powertrain has been built to work together in perfect harmony. The Volvo design has been rigorously tested to deliver optimized performance, high productivity, low fuel consumption and superior reliability.



#### Attachments

Volvo's wide range of durable attachments have been purpose-built to work in perfect harmony with Volvo machines. The attachments are designed as an integrated part of the wheel loader for which they're intended – with functions and properties perfectly matched to parameters including link-arm geometry and breakout, rim pull and lifting force.

# Get the job done with Volvo.

Maximize your productivity and profitability with the L110H, L120H and Volvo's comprehensive range of attachments. Increase your versatility, access more applications and effectively perform a variety of tasks – all while experiencing short cycle times, high lifting forces and excellent controllability.



## Torque Parallel linkage

Volvo's unique Torque Parallel (TP) linkage delivers high breakout torque and excellent parallel movement throughout the entire lifting range.

## Boom Suspension System

The optional Boom Suspension System (BSS) boosts productivity by up to 20% by absorbing shock and reducing the bouncing and bucket spillage that occurs when operating on rough ground. This enables faster and more comfortable work cycles and increases machine life.



# Fully loaded.

## Information panel

The display clearly presents the operator with vital machine information including fuel levels and warning messages.



## Cab

The certified ROPS/FOPS cab features ergonomically placed controls, a superior climate control system, all-around visibility and low internal noise levels.



## TP linkage

Volvo's unique Torque Parallel (TP) linkage delivers high breakout torque and excellent parallel movement through the entire lifting range.



## OptiShift

Volvo's optional OptiShift technology reduces fuel consumption by up to 18%, increases operator comfort and reduces stress in the drivetrain.

## Intelligent hydraulics

Volvo's load-sensing hydraulics supply power to the hydraulic functions according to demand, lowering fuel consumption.



## Attachments

Volvo's wide range of durable attachments have been purpose-built to deliver maximum productivity with Volvo machines.



### **Single lever**

The optional, multi-functional joystick gives the operator simultaneous and precise control of the linkage.

### **Diesel Exhaust Fluid (DEF)**

Volvo offers a total DEF solution that is quality assured, cost efficient and easily accessible. Contact your Volvo dealer for more information.

### **Easy service access**

Electrically actuated, wide-opening engine hood allows quick and easy service access to the engine compartment.

### **Volvo engine**

Volvo's powerful Tier 4 Final/Stage IV engine delivers the ultimate combination of high performance and low fuel consumption.



### **Powertrain**

The ideally-matched, all-Volvo powertrain has been built to work together in perfect harmony – ensuring optimized performance.

# Adding value to your business.

Being a Volvo customer means having a complete set of services at your fingertips. Volvo can offer you a long-term partnership, protect your revenue and provide a full range of customer solutions using high quality parts, delivered by passionate people. Volvo is committed to the positive return of your investment.



## Complete Solutions

Volvo has the right solution for you. So why not let us provide all your needs throughout the whole life cycle of

your machine? By listening to your requirements, we can reduce your total cost of ownership and increase your revenue.



## Genuine Volvo Parts

Our attention to detail is what makes us stand out. This proven concept acts as a solid investment in your machine's future. Parts are extensively tested and approved because every part is vital for uptime and performance. Only by using Genuine Volvo Parts, can you be sure that your machine retains the renowned Volvo quality.



## Service Network

In order to respond to your needs faster, a Volvo expert is on their way to your job site from one of our Volvo facilities. With our extensive infrastructure of technicians, workshops and dealers, Volvo has a comprehensive network to fully support you using local knowledge and global experience.



## PROFITABILITY



## SERVICE PLAN

DAY01	DAY02	DAY03	DAY04	DAY05	DAY06	DAY07
						✓
			✓	✓		
	✓					
		✓				✓
✓						
		✓				✓

## FUEL CONSUMPTION



### Customer Support Agreements

The range of Customer Support Agreements offer preventive maintenance, total repairs and a number of uptime services. Volvo uses the latest technology to monitor machine operation and status, giving you advice to increase your profitability. By having a Customer Support Agreement you are in control of your service costs.

# Volvo L110H, L120H in detail.

## Engine

The engine is a straight six cylinder, four stroke, turbo charged diesel engine with direct injection and charge air cooler. The engine meet US Tier 4 final and California Tier 4 final emission requirements and EU Stage IV emission requirements.

The engine uses a common rail fuel system controlled by the engine control module (ECM). Engines with ACT (advanced combustion technology) feature split injection and turbocharger with mechanical wastegate. The exhaust after treatment system (EATS) is equipped with a diesel oxidation catalyst (DOC), a diesel particulate filter (DPF) and a SCR system to reduce emissions. Cooled exhaust gas recirculation (EGR) also reduces emissions.

## L110H

Engine	D8J (Tier 4f)		
	D8J (Stage IV)		
Max power at	r/s (r/min)	30 (1 800)	
SAE J1995 gross	kW (hp)	191 (259)	
ISO 9249, SAE J1349 net	kW (hp)	190 (258)	
Max torque at	r/s (r/min)	24.1 (1 450)	
SAE J1995 gross	Nm lbf-ft	1 255	926
ISO 9249, SAE J1349 net	Nm lbf-ft	1 250	922
Economic working range	r/s (r/min)	14.2-35 (850-2 100)	
Displacement	l gal	7.75	2

## L120H

Engine	D8J (Tier 4f)		
	D8J (Stage IV)		
Max power at	r/s (r/min)	25 (1 500)	
SAE J1995 gross	kW (hp)	203 (276)	
ISO 9249, SAE J1349 net	kW (hp)	203 (276)	
Max torque at	r/s (r/min)	24.1 (1 450)	
SAE J1995 gross	Nm lbf-ft	1 320	973
ISO 9249, SAE J1349 net	Nm lbf-ft	1 317	971
Economic working range	r/s (r/min)	14.2-35 (850-2 100)	
Displacement	l gal	7.75	2

## L110H

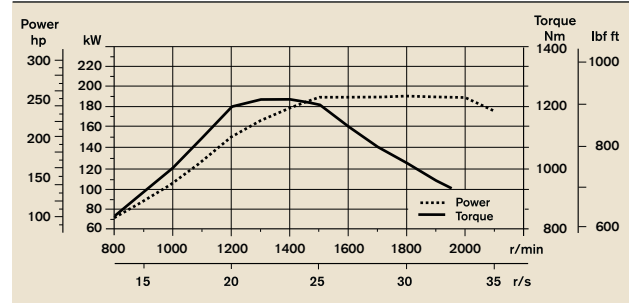

## L120H

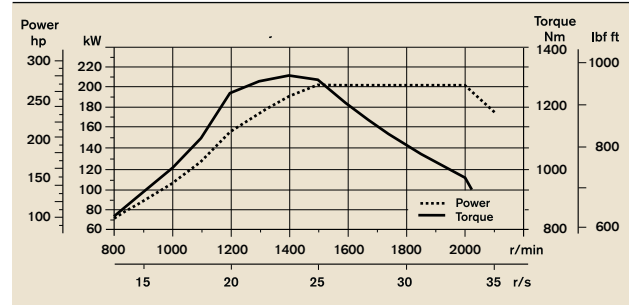

## Drivetrain

**Torque converter:** Single-stage.

**Transmission:** Volvo countershaft transmission with single lever control. Fast and smooth shifting of gears with Pulse Width Modulation (PWM) valve.

**Transmission:** Volvo Automatic Power Shift (APS) with fully automatic shifting 1-4 and mode selector with 4 different gear shifting programs, including AUTO. OptiShift transmission is also available as an option.

**Axles:** Volvo fully floating axle shafts with planetary hub reductions and cast steel axle housing. Fixed front axle and oscillating rear axle. 100% differential lock on the front axle.

### L110H

Transmission	Volvo	HTE 206C			
Torque multiplication, stall ratio		2.47:1			
Maximum speed, forward/reverse	1st gear	km/h	mph	7	4.35
	2nd gear	km/h	mph	13.5	8.1
	3rd gear	km/h	mph	28	17.4
	4th gear*	km/h	mph	40	24.9
Measured with tires		750/65R25			
Front axle/rear axle		AWB 31/AWB 30			
Rear axle oscillation ±		°		± 13	
Ground clearance at 13° osc.	mm	in	460	18.1	

### L120H

Transmission	Volvo	HTE 206C			
Torque multiplication		2.47:1			
Maximum speed, forward/reverse	1st gear	km/h	mph	7	4.35
	2nd gear	km/h	mph	13.5	8.1
	3rd gear	km/h	mph	28	17.4
	4th gear*	km/h	mph	40	24.9
Measured with tires		750/65R25			
Front axle/rear axle		AWB 31/AWB 30			
Rear axle oscillation ±		°		± 13	
Ground clearance at 15° osc.	mm	in	460	18.1	

\* limited by ECU

## Electrical system

**Central warning system:** Contronic electrical system with central warning light and buzzer for following functions: - Serious engine fault - Low steering system pressure - Over speed warning engine - Interruption in communication (computer fault) Central warning light and buzzer with the gear engaged for the following functions. - Low engine oil pressure - High engine oil temperature - High charge air temperature - Low coolant level - High coolant temperature - High crank case pressure - Low transmission oil pressure - High transmission oil temperature - Low brake pressure - Engaged parking brake - Fault on brake charging - Low hydraulic oil level - High hydraulic oil temperature - Overspeeding in engaged gear - High brake cooling oil temperature front and rear axles.

### L110H, L120H

Voltage	V	24
Batteries	V	2 x 12
Battery capacity	Ah	2 x 170
Cold cranking capacity, approx	A	1 000
Alternator rating	W/A	2 280/80
Starter motor output	kW	5.5

## Brake system

**Service brake:** Volvo dual-circuit system with nitrogen charged accumulators. Outboard mounted hydraulically operated, fully sealed oil circulation cooled wet disc brakes. The operator can select automatic declutch of the transmission when braking by selecting the setting in the contronics.

**Parking brake:** Fully sealed, wet multi-disc brake built into the transmission. Applied by spring force and disengaged by external hydraulic pressure. The parking brake is activated and deactivated through a switch in the dashboard.

**Secondary brake:** Dual brake circuits with rechargeable accumulators. One circuit or the parking brake fulfills all safety requirements.

**Standard:** The brake system complies with the requirements of ISO 3450.

### L110H

Number of brake discs per wheel front		1
Accumulators	l US gal	3 x 1.0 0.26

### L120H

Number of brake discs per wheel front		1
Accumulators	l US gal	3 x 1.0 0.26

# Volvo L110H, L120H in detail.

## Cab

**Instrumentation:** All important information is centrally located in the operator's field of vision. Display for Contronic monitoring system.

**Heater and defroster:** Heater coil with filtered fresh air and fan with auto and manual(11 speed) setting. Defroster vents for all window areas.

**Operator's seat:** Operator's seat with adjustable suspension and retractable seatbelt. The seat is mounted on a bracket on the rear cab wall and floor. The forces from the retractable seatbelt are absorbed by the seat rails.

**Standard:** The cab is tested and approved according to ROPS (ISO 3471, SAE J1040), FOPS (ISO 3449). The cab meets with requirements according to ISO 6055 (Operator overhead protection - Industrial trucks) and SAE J386 ("Operator Restraint System").

### L110H

Emergency exit: Use emergency hammer to break window			
Sound level in cab according to SO 6396/SAE J2105	dB(A)	68	
External sound level according to ISO 6396/SAE J2105	dB(A)	106	
Ventilation	m <sup>3</sup> /min	yd <sup>3</sup> /min	9 11.8
Heating capacity	kW		16
Air conditioning (optional)	kW		7.5

### L120H

Emergency exit: Use emergency hammer to break window			
Sound level in cab according to ISO 6396/SAE J2105	dB(A)	68	
External sound level according to ISO 6395/SAE J2104	dB(A)	106	
Ventilation	m <sup>3</sup> /min	yd <sup>3</sup> /min	9 11.8
Heating capacity	kW		16
Air conditioning (optional)	kW		7.5

## Lift arm system

Torque Parallel linkage (TP-linkage) with high breakout torque and parallel movement throughout the entire lifting range.

### L110H

Lift cylinders			2	
Cylinder bore	mm	in	150	5.9
Piston rod diameter	mm	in	80	3.1
Stroke	mm	in	676	26.6
Tilt cylinder			1	
Cylinder bore	mm	in	210	8.3
Piston rod diameter	mm	in	110	4.3
Stroke	mm	in	412	16.2

### L120H

Lift cylinders			2	
Cylinder bore	mm	in	150	5.9
Piston rod diameter	mm	in	80	3.1
Stroke	mm	in	676	26.6
Tilt cylinder			1	
Cylinder bore	mm	in	210	8.3
Piston rod diameter	mm	in	110	4.3
Stroke	mm	in	412	16.2

## Hydraulic system

**System supply:** Two load-sensing axial piston pumps with variable displacement. The steering system always has priority.

**Valves:** Double-acting 2-spool valve. The main valve is controlled by a 2-spool pilot valve.

**Lift function:** The valve has four positions; raise, hold, lower and floating position. Inductive/magnetic automatic boom kickout can be switched on and off and is adjustable to any position between maximum reach and full lifting height.

**Tilt function:** The valve has three functions including rollback, hold and dump. Inductive/magnetic automatic tilt can be adjusted to the desired bucket angle.

**Cylinders:** Double-acting cylinders for all functions

**Filter:** Full flow filtration through 10 micron (absolute) filter cartridge.

				L110H		L120H	
Working pressure maximum, pump 1 for working hydraulic system		MPa	bar	27.0 ± 0.5	270 ± 0.5	29.0 ± 0.5	290 ± 0.5
Flow		l/min	gal/min	128	33.8	128	33.8
at		MPa	bar	10	100	10	100
engine speed		r/s(r/min)		32 (1 900)		32 (1 900)	
Working pressure maximum, pump 2 for steering-, brake-, pilot- and working hydraulic system		MPa	bar	29.0 ± 0.5	290 ± 0.5	31.0 ± 0.5	310 ± 0.5
Flow		l/min	gal/min	128	33.8	128	33.8
at		MPa	bar	10	100	10	100
engine speed		r/s(r/min)		32 (1 900)		32 (1 900)	
Working pressure maximum, pump 3 for brake- and cooling fan system		MPa	bar	21.0 ± 0.5	210 ± 0.5	21.0 ± 0.5	210 ± 0.5
Flow		l/min	gal/min	33	8.7	33	8.7
at		MPa	bar	10	100	10	100
engine speed		r/s(r/min)		32 (1 900)		32 (1 900)	
Pilot system, working pressure		MPa	bar	3.5	35	3.5	35
Cycle times							
Lift			s		5.4		5.4
Tilt			s		2.1		2.1
Lower, empty			s		2.5		2.5
Total cycle time			s		10.0		10.0

## Steering system

**Steering system:** Load-sensing hydrostatic articulated steering.

**System supply:** The steering system has priority feed from a load-sensing axial piston pump with variable displacement.

**Steering cylinders:** Two double-acting cylinders.

				L110H		L120H	
Steering cylinders				2		2	
Cylinder bore		mm	in	80	3.1	80	3.1
Rod diameter		mm	in	50	2.0	50	2.0
Stroke		mm	in	486	19.1	486	19.1
Working pressure		MPa	in	21	210	21	210
Maximum flow		l/min	gal/min	120	31.7	120	31.7
Maximum articulation			± °		40		40

## Service

**Service accessibility:** Electrically openable engine hood with large opening angle giving excellent access to the engine compartment.

Fluid filters and component breather air filters promote long service intervals.

Possibility to monitor, log and analyze data to facilitate troubleshooting.

				L110H		L120H	
Refill capacity							
Fuel tank		l	gal	270	71.3	270	71.3
Diesel Exhaust Fluid tank		l	gal	24.9	6.5	24.9	6.5
Engine coolant		l	gal	43	11.4	43	11.4
Hydraulic oil tank		l	gal	133	35.1	133	35.1
Transmission oil		l	gal	38	10	38	10
Engine oil		l	gal	22	5.8	22	5.8
Axle oil front		l	gal	36	9.5	36	9.5
Axle oil rear		l	gal	41	10.8	41	10.8

# Specifications L110H.

## Tires 23.5 R25 L3

			Standard boom		Long boom	
B	mm	ft in	6 480	21'3"	7 010	23'0"
C	mm	ft in	3 200	10'6"	3 200	10'6"
D	mm	ft in	430	1'5"	430	1'5"
F	mm	ft in	3 380	11'1"	3 380	11'1"
G	mm	ft in	2 131	7'0"	2 134	7'0"
J	mm	ft in	3 700	12'2"	4 240	13'11"
K	mm	ft in	4 030	13'3"	4 550	14'11"
O	°			55		54
Pmax	°			50		46
R	°			40		41
R <sub>1</sub> *	°			44		48
S	°			66		64
T	mm	ft in	98	0'3.9"	89	0'3.5"
U	mm	ft in	430	1'5"	610	2'0"
X	mm	ft in	2 070	6'9"	2 070	6'9"
Y	mm	ft in	2 670	8'9"	2 670	8'9"
Z	mm	ft in	3 310	10'10"	3 820	12'6"
a <sub>2</sub>	mm	ft in	5 730	18'10"	5 730	18'10"
a <sub>3</sub>	mm	ft in	3 060	10'1"	3 060	10'1"
a <sub>4</sub>		±°		40		40

\* Carry position SAE

Standard boom with 3.0 m<sup>3</sup> / 3.9 yd<sup>3</sup> STE H T bucket

Long boom with 2.6 m<sup>3</sup> / 3.4 yd<sup>3</sup> STE P BOE bucket

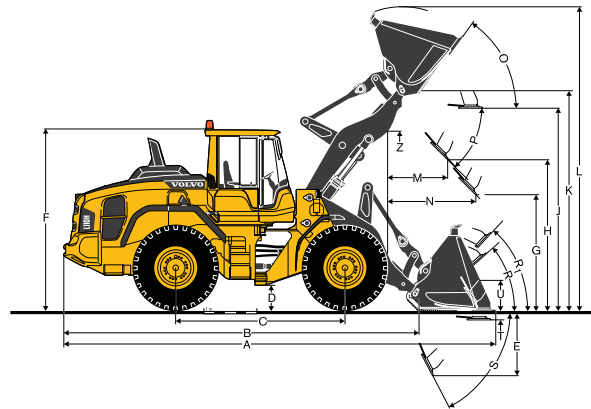

Where applicable, specifications and dimensions are according to ISO 7131, SAE J732, ISO 7546, SAE J742, ISO 14397, SAE J818.

## L110H

Sales code: WLA80832

Operating weight

(incl. logging cw 685 kg / 1,510 lb): 19 916 kg / 43,920 lb

Operating load: 5 850 kg / 12,900 lb

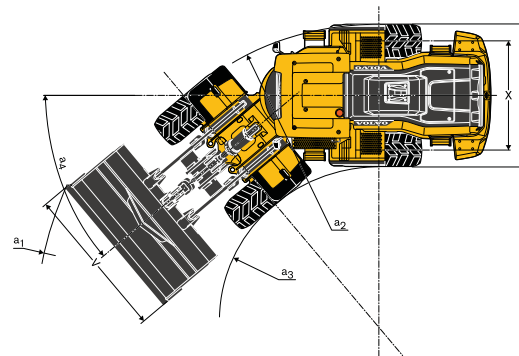

## Tires: 750/65 R25

A	m <sup>2</sup>	ft <sup>2</sup>		2.4	25.8
B	mm	in		3 470	11'5"
C	mm	in		1 850	6'1"
D	mm	in		2 850	9'4"
E	mm	in		1 460	4'10"
F	mm	in		1 520	5'0"
G	mm	in		2 720	8'11"
H	mm	in		4 580	15'0"
I	mm	in		6 620	21'9"
J	mm	in		2 790	9'2"
K	mm	in		2 990	9'10"
L	mm	in		2 060	6'9"
M	mm	in		8 770	28'9"

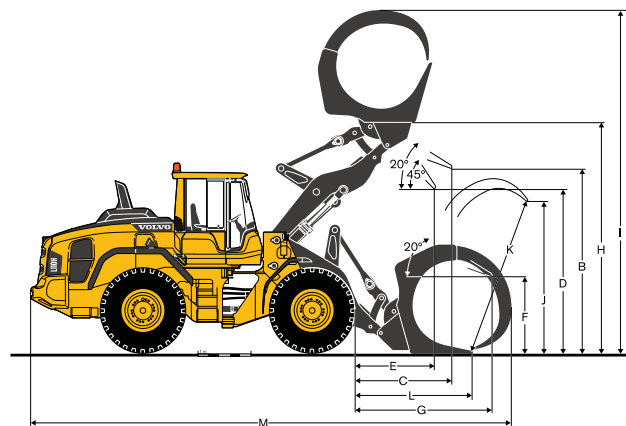

**L110H**

Tires 23.5R25 XHA2 L3	REHANDLING				GENERAL PURPOSE				ROCK*		LIGHT MATERIAL				LONG BOOM**	
	3.5 m³ 4.6 yd³ STE P BOE	3.5 m³ 4.6 yd³ STE H BOE	3.0 m³ 3.9 yd³ STE P T	3.0 m³ 3.9 yd³ STE H T	3.4 m³ 4.4 yd³ STE P BOE	3.4 m³ 4.4 yd³ STE H BOE	2.7 m³ 3.5 yd³ SPN P T SEG	5.5 m³ 7.2 yd³ LM H	9.5 m³ 12.4 yd³ LM H							
Volume, heaped ISO/SAE	m³ yd³	3.5 4.6	3.5 4.6	3.0 3.9	3.0 3.9	3.4 4.4	3.4 4.4	2.7 3.5	5.5 7.2	9.5 12.4						
Volume at 110% fill factor	m³ yd³	3.9 5.0	3.9 5.0	3.3 4.3	3.3 4.3	3.7 4.9	3.7 4.9	3.0 3.9	6.1 7.9	10.5 13.7						
Static tipping load, straight	kg lb	13 460 29,670	12 780 28,190	13 770 30,370	13 100 28,890	13 350 29,430	12 680 27,960	13 780 30,390	11 980 26,410	12 070 26,620	-2 540 -5 588					
at 35° turn	kg lb	11 960 26,370	11 330 24,990	12 270 27,050	11 640 25,670	11 860 26,140	11 240 24,780	12 240 26,980	10 550 23,260	10 610 23,400	-2 330 -5 126					
at full turn	kg lb	11 520 25,390	10 900 24,040	11 820 26,070	11 210 24,720	11 420 25,170	10 810 23,830	11 780 25,970	10 130 22,340	10 180 22,450	-2 270 -4 994					
Breakout force	kN lb	162.1 36,440	149.8 33,680	175.8 39,530	161.0 36,210	157.7 35,460	145.9 32,800	143.1 32,170	115.0 25,850	100.3 22,550						
A	mm ft in	7 970 26'2"	8 080 26'6"	8 120 26'8"	8 220 27'0"	8 010 26'3"	8 120 26'8"	8 310 27'3"	8 500 27'11"	8 800 28'10"	510 1'8"					
E	mm ft in	1 220 4'0"	1 320 4'4"	1 350 4'5"	1 450 4'9"	1 260 4'2"	1 360 4'6"	1 510 5'0"	1 700 5'7"	1 960 6'5"	-10 -4/10"					
H	mm ft in	2 820 9'3"	2 750 9'0"	2 720 8'11"	2 660 8'9"	2 790 9'2"	2 720 8'11"	2 610 8'7"	2 420 7'11"	2 220 7'3"	510 1'8"					
L	mm ft in	5 440 17'10"	5 510 18'1"	5 550 18'2"	5 610 18'5"	5 620 18'5"	5 670 18'7"	5 550 18'2"	5 850 19'2"	6 010 19'9"	520 1'9"					
M	mm ft in	1 170 3'10"	1 250 4'1"	1 260 4'2"	1 350 4'5"	1 200 3'11"	1 280 4'2"	1 400 4'7"	1 520 5'0"	1 730 5'8"	-30 -0'1"					
N	mm ft in	1 710 5'7"	1 750 5'9"	1 750 5'9"	1 800 5'11"	1 730 5'8"	1 770 5'9"	1 810 5'11"	1 800 5'11"	1 820 6'0"	450 1'6"					
V	mm ft in	3 000 118"	3 000 118"	2 880 113"	2 880 113"	2 880 113"	2 880 113"	2 880 113"	3 000 118"	3 400 133"						
a, clearance circle	mm ft in	12 750 41'10"	12 800 42'0"	12 710 41'8"	12 770 41'11"	12 660 41'6"	12 710 41'8"	12 830 42'1"	13 060 42'10"	13 610 44'8"	440 1'5"					
Operating weight	kg lb	18 490 40,770	18 730 41,290	18 360 40,480	18 560 40,930	18 560 40,920	18 760 41,370	19 560 43,130	19 100 42,120	19 320 42,610	300 660					

\* With MICHELIN 23,5R25 XMINE D2 L5 Tire

\*\* Based on 3.0 m³ / 3.9 yd³ STE H T bucket

**Bucket Selection Chart**

The chosen bucket is determined by the density of the material and the expected bucket fill factor. The actual bucket volume is often larger than the rated capacity, due to the features of the TP linkage, including an open bucket design, good rollback angles in all positions and good bucket filling performance. The example represents a standard boom configuration.  
 Example: Sand and gravel. Fill factor ~ 105%. Density 1.6 t/m³ (2,700 lb/yd³).  
 Result: The 3.4 m³(4.5 yd³) bucket carries 3.6 m³ (4.7 yd³). For optimum stability always consult the bucket selection chart.

Material	Bucket fill, %		Material density		ISO/SAE bucket volume		Actual volume	
			t/m³	lb/yd³	m³	yd³	m³	yd³
Earth/Clay	~ 110		1.8	3,030	3.0	3.9	3.3	4.3
			1.6	2,700	3.4	4.5	3.7	4.8
Sand/Gravel	~ 105		1.8	3,030	3.0	3.9	3.2	4.2
			1.6	2,700	3.4	4.5	3.6	4.7
Aggregate	~ 100		1.8	3,030	3.5	4.6	3.5	4.6
			1.6	2,700				
Rock	≤100		1.7	2,866	2.7	3.5	2.7	3.5

The size of rock buckets is optimized for optimal penetration and filling capability rather than the density of the material.

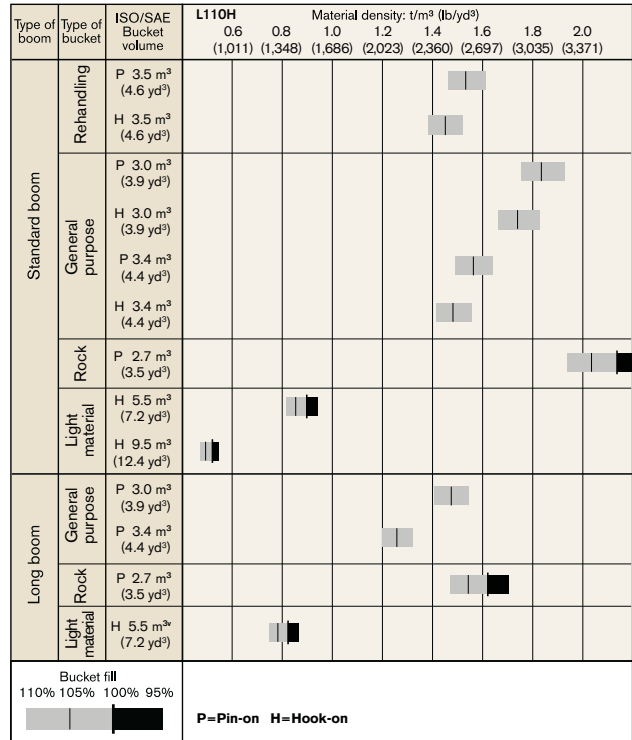

How to read bucket fill factor

**Supplemental Operating Data**

Tires 23.5 R25 L3	Standard boom				Long boom			
	23.5 R25 L5		750/65 R25		750/65 R25		750/65 R25	
Width over tires	mm	in	30	1.2	200	7.9	200	7.9
Ground clearance	mm	in	50	2	±0	±0	±0	±0
Tipping load, full turn	kg	lb	490	1,078	430	946	310	682
Operating weight	kg	lb	670	1,474	640	1,408	640	1,408

# Specifications L120H.

## Tires 23.5 R25 L3

			Standard boom		Long boom	
B	mm	ft in	6 580	21'7"	7 070	23'2"
C	mm	ft in	3 200	10'6"	3 200	10'6"
D	mm	ft in	440	1'5"	440	1'5"
F	mm	ft in	3 380	11'1"	3 390	11'1"
G	mm	ft in	2 132	7'0"	2 133	7'0"
J	mm	ft in	3 760	12'4"	4 310	14'2"
K	mm	ft in	4 100	13'5"	4 630	15'2"
O	°			54		55
Pmax	°			50		49
R	°			42		42
R <sub>1</sub> *	°			45		50
S	°			68		64
T	mm	ft in	119	0'4.7"	127	0'5"
U	mm	ft in	450	1'6"	640	2'1"
X	mm	ft in	2 070	6'9"	2 070	6'9"
Y	mm	ft in	2 670	8'9"	2 670	8'9"
Z	mm	ft in	3 340	10'11"	3 720	12'3"
a <sub>2</sub>	mm	ft in	5 730	18'10"	5 730	18'10"
a <sub>3</sub>	mm	ft in	3 060	10'1"	3 060	10'1"
a <sub>4</sub>		±°		40		40

\* Carry position SAE

Standard boom with 3.3 m<sup>3</sup> / 4.3 yd<sup>3</sup> STE H T bucket

Long boom with 2.6 m<sup>3</sup> / 3.4 yd<sup>3</sup> STE P BOE bucket

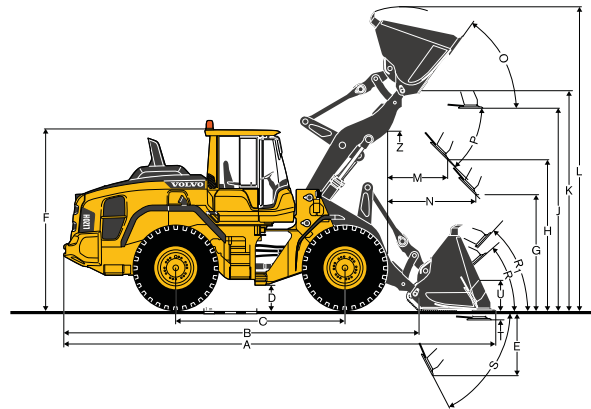

Where applicable, specifications and dimensions are according to ISO 7131, SAE J732, ISO 7546, SAE J742, ISO 14397, SAE J818.

## L120H

Sales code: WLA80832

Operating weight

(incl. logging cw 685 kg / 1,510 lb): 20 713 kg / 45,660 lb

Operating load: 6 400 kg / 14,110 lb

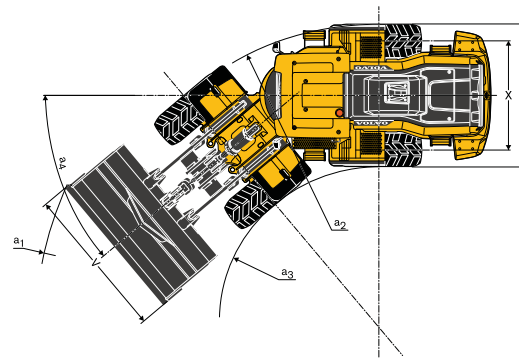





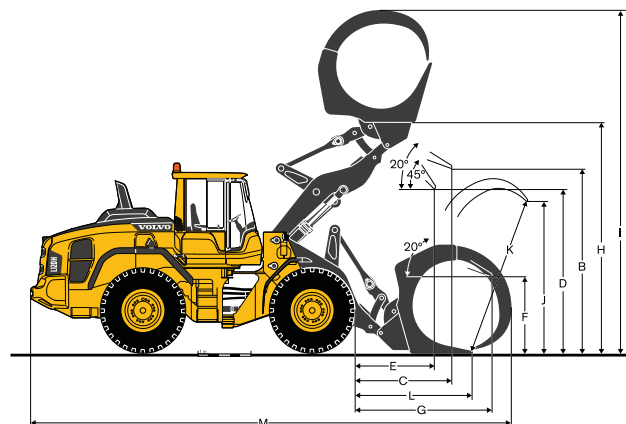





## Tires: 750/65 R25

A	m <sup>2</sup>	ft <sup>2</sup>		2.4	25.8
B	mm	in		3 470	11'8"
C	mm	in		1 850	6'2"
D	mm	in		2 850	9'7"
E	mm	in		1 460	4'11"
F	mm	in		1 520	5'0"
G	mm	in		2 720	9'2"
H	mm	in		4 580	15'3"
I	mm	in		6 620	21'11"
J	mm	in		2 790	9'2"
K	mm	in		2 990	9'10"
L	mm	in		2 060	7'1"
M	mm	in		8 770	29'1"



## L120H





Tires 23.5R25 XHA2 L3	REHANDLING				GENERAL PURPOSE				ROCK*		LIGHT MATERIAL			LONG BOOM**	
															
	3.8 m <sup>3</sup> 5.0 yd <sup>3</sup> STE P BOE	3.8 m <sup>3</sup> 5.0 yd <sup>3</sup> STE H BOE	3.3 m <sup>3</sup> 4.3 yd <sup>3</sup> STE P T	3.3 m <sup>3</sup> 4.3 yd <sup>3</sup> STE H T	3.6 m <sup>3</sup> 4.7 yd <sup>3</sup> STE P BOE	3.6 m <sup>3</sup> 4.7 yd <sup>3</sup> STE H BOE	3.0 m <sup>3</sup> 3.9 yd <sup>3</sup> SPN P T SEG	5.5 m <sup>3</sup> 7.2 yd <sup>3</sup> LM H	9.5 m <sup>3</sup> 12.4 yd <sup>3</sup> LM H						
Volume, heaped ISO/SAE	m <sup>3</sup> yd <sup>3</sup>	3.8 5.0	3.8 5.0	3.3 4.3	3.3 4.3	3.6 4.7	3.6 4.7	3.0 3.9	5.5 7.2	9.5 12.4					
Volume at 110% fill factor	m <sup>3</sup> yd <sup>3</sup>	4.2 5.5	4.2 5.5	3.6 4.7	3.6 4.7	4.0 5.2	4.0 5.2	3.3 4.3	6.1 7.9	10.5 13.7					
Static tipping load, straight	kg lb	14 360 31,660	13 680 30,160	14 800 32,630	14 450 31,870	14 810 32,660	14 080 31,040	14 860 32,760	13 010 28,690	13 120 28,940	-2 680 -5,896				
at 35° turn	kg lb	12 710 28,030	12 080 26,630	13 120 28,940	12 790 28,210	13 110 28,920	12 430 27,410	13 160 29,020	11 440 25,230	11 510 25,390	-2 440 -5,368				
at full turn	kg lb	12 220 26,950	11 610 25,590	12 630 27,850	12 300 27,120	12 610 27,810	11 950 26,340	12 660 27,920	10 980 24,200	11 040 24,340	-2 370 -5,214				
Breakout force	kN lb	163.7 36,820	151.6 34,090	189.2 42,530	173.5 39,010	172.9 38,870	159.6 35,880	150.6 33,870	121.6 27,340	106.0 23,840					
A	mm ft in	8 140 26'8"	8 240 27'0"	8 230 27'0"	8 340 27'4"	8 050 26'5"	8 160 26'9"	8 390 27'6"	8 610 28'3"	8 910 29'3"	460 1'6"				
E	mm ft in	1 300 4'3"	1 390 4'7"	1 380 4'6"	1 480 4'10"	1 230 4'0"	1 330 4'4"	1 520 5'0"	1 730 5'8"	1 990 6'6"	-20 -8/10"				
H	mm ft in	2 840 9'4"	2 780 9'1"	2 780 9'1"	2 700 8'10"	2 900 9'6"	2 830 9'3"	2 690 8'10"	2 480 8'2"	2 270 7'6"	560 1'10"				
L	mm ft in	5 580 18'4"	5 650 18'6"	5 700 18'8"	5 760 18'11"	5 750 18'10"	5 820 19'1"	5 690 18'8"	5 900 19'4"	6 070 19'11"	520 1'9"				
M	mm ft in	1 250 4'1"	1 330 4'4"	1 310 4'3"	1 390 4'7"	1 190 3'11"	1 280 4'2"	1 440 4'9"	1 560 5'1"	1 760 5'9"	-50 -0'2"				
N	mm ft in	1 820 6'0"	1 870 6'1"	1 840 6'0"	1 880 6'2"	1 800 5'11"	1 840 6'0"	1 930 6'4"	1 890 6'2"	1 910 6'3"	450 1'6"				
V	mm ft in	3 000 118"	3 000 118"	3 000 118"	3 000 118"	3 000 118"	3 000 118"	2 880 113"	3 000 118"	3 400 133"					
a, clearance circle	mm ft in	12 840 42'2"	12 900 42'4"	12 890 42'3"	12 950 42'6"	12 800 42'0"	12 850 42'2"	12 890 42'3"	13 130 43'1"	13 660 44'10"	410 1'4"				
Operating weight	kg lb	19 370 42,710	19 590 43,200	19 280 42,510	19 460 42,900	19 420 42,830	19 640 43,300	20 260 44,680	19 900 43,880	20 120 44,360	240 528				

\* With MICHELIN 23,5R25 XMINE D2 L5 Tire

\*\* Based on 3,3 m<sup>3</sup> / 4.3 yd<sup>3</sup> STE H T bucket

### Bucket Selection Chart

The chosen bucket is determined by the density of the material and the expected bucket fill factor. The actual bucket volume is often larger than the rated capacity, due to the features of the TP linkage, including an open bucket design, good rollback angles in all positions and good bucket filling performance. The example represents a standard boom configuration.  
 Example: Sand and gravel. Fill factor ~ 105%. Density 1.6 t/m<sup>3</sup> (2,700 lb/yd<sup>3</sup>).  
 Result: The 3.4 m<sup>3</sup>(4.5 yd<sup>3</sup>) bucket carries 3.6 m<sup>3</sup> (4.7 yd<sup>3</sup>). For optimum stability always consult the bucket selection chart.

Material	Bucket fill, %		Material density		ISO/SAE bucket volume		Actual volume	
			t/m <sup>3</sup>	lb/yd <sup>3</sup>	m <sup>3</sup>	yd <sup>3</sup>	m <sup>3</sup>	yd <sup>3</sup>
Earth/Clay	~ 110		1.8	3,030	3.3	4.3	3.6	4.7
			1.6	2,700	3.6	4.7	3.9	5.1
Sand/Gravel	~ 105		1.8	3,030	3.3	4.3	3.5	4.6
			1.6	2,700	3.6	4.7	3.8	5.0
Aggregate	~ 100		1.8	3,030	3.8	5.0	3.8	5.0
			1.6	2,700				
Rock	≤100		1.7	2,866	3.0	3.9	3.0	3.9

The size of rock buckets is optimized for optimal penetration and filling capability rather than the density of the material.

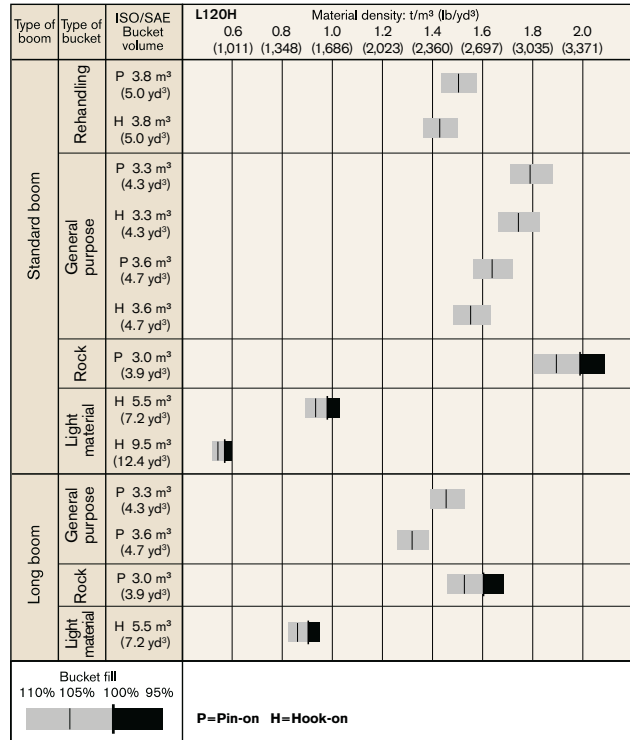

How to read bucket fill factor

### Supplemental Operating Data

Tires 23.5 R25 L3	Standard boom				Long boom			
	23.5 R25 L5		750/65 R25		750/65 R25		750/65 R25	
Width over tires	mm	in	30	1.2	200	7.9	200	7.9
Ground clearance	mm	in	50	2	±0	±0	±0	±0
Tipping load, full turn	kg	lb	450	990	380	836	330	726
Operating weight	kg	lb	670	1,474	640	1,408	640	1,408

# Equipment.

STANDARD EQUIPMENT		
	L110H	L120H
<b>Service and maintenance</b>		
Engine oil remote drain and fill	•	•
Transmission oil remote drain and fill	•	•
Lubrication manifolds, ground accessible	•	•
Pressure check connections: transmission and hydraulic, quick-connects	•	•
Tool box, lockable	•	•
<b>Engine</b>		
Exhaust after-treatment system	•	•
Three stage air cleaner, pre-cleaner, primary and secondary filter	•	•
Indicator for coolant level	•	•
Preheating of induction air	•	•
Fuel pre-filter with water trap	•	•
Fuel filter	•	•
Crankcase breather oil trap	•	•
Exterior radiator air intake protection	•	•
<b>Electrical system</b>		
24 V, pre-wired for optional accessories	•	•
Alternator 24V/80A/2280W	•	•
Battery disconnect switch	•	•
Fuel gauge	•	•
Hour meter	•	•
Electric horn	•	•
Instrument cluster:		
Fuel level		
Diesel Exhaust Fluid/AdBlue level	•	•
Transmission temperature		
Coolant temperature		
Instrument lighting		
Lighting:		
Twin halogen front headlights with high and low beams		
Parking lights	•	•
Double brake and tail lights		
Turn signals with flashing hazard light function		
Halogen work lights (2 front and 2 rear)		

	L110H	L120H
<b>Conronic monitoring system</b>		
Monitoring and logging of machine data	•	•
Conronic display	•	•
Fuel consumption	•	•
Diesel Exhaust Fluid/AdBlue consumption	•	•
Ambient temperature	•	•
Clock	•	•
Test function for warning and indicator lights	•	•
Brake test	•	•
Test function, sound level at max fan speed	•	•
Warning and indicator lights:		
Battery charging	•	•
Parking brake		
Warning and display message:		
Regeneration		
Engine coolant temperature		
Charge-air temperature		
Engine oil temperature		
Engine oil pressure		
Transmission oil temperature		
Transmission oil pressure		
Hydraulic oil temperature	•	•
Brake pressure		
Parking brake applied		
Brake charging		
Overspeed at direction change		
Axle oil temperature		
Steering pressure		
Crankcase pressure		
Attachment lock open		
Safety Belt Warning		
Level warnings:		
Fuel level		
Diesel Exhaust Fluid/AdBlue level		
Engine oil level	•	•
Engine coolant level		
Transmission oil level		
Hydraulic oil level		
Washer fluid level		
Engine torque reduction in case of malfunction indication:		
High engine coolant temperature		
High engine oil temperature	•	•
Low engine oil pressure		
High crankcase pressure		
High charge-air temperature		
Engine shutdown to idle in case of malfunction indication:		
High transmission oil temperature	•	•
Slip in transmission clutches		
Keypad, background lit	•	•
Start interlock when gear is engaged	•	•

	L110H	L120H
<b>Drivetrain</b>		
Automatic Power Shift	•	•
Fully automatic gearshifting, 1-4	•	•
PWM-controlled gearshifting	•	•
Forward and reverse switch by hydraulic lever console	•	•
Indicator glass for transmission oil level	•	•
Differentials: Front, 100% hydraulic diff lock. Rear, conventional.	•	•
Lock-up first gear	•	•
<b>Brake system</b>		
Dual brake circuits	•	•
Dual brake pedals	•	•
Secondary brake system	•	•
Parking brake, electro-hydraulic	•	•
Brake wear indicators	•	•
<b>Cab</b>		
ROPS (ISO 3471), FOPS (ISO 3449)	•	•
Single key kit door/start	•	•
Acoustic inner lining	•	•
Cigarette lighter, 24 V power outlet	•	•
Lockable door	•	•
Cab heating with fresh air inlet and defroster	•	•
Fresh air inlet with two filters	•	•
Automatic heat control	•	•
Floor mat	•	•
Dual interior lights	•	•
Interior rear-view mirrors	•	•
Dual exterior rear-view mirrors	•	•
Sliding window, right side	•	•
Tinted windshield glass	•	•
Retractable seatbelt (SAE J386)	•	•
Adjustable steering wheel	•	•
Storage compartment	•	•
Document pocket	•	•
Sun visor	•	•
Beverage holder	•	•
Windshield washer front and rear	•	•
Windshield wipers front and rear	•	•
Interval function for front and rear wipers	•	•

	L110H	L120H
<b>Hydraulic system</b>		
Main valve, double acting 2-spool with hydraulic pilots	•	•
Variable displacement axial piston pumps (3) for:		
1 Working hydraulics, Pilot hydraulics and Brake system	•	•
2 Working hydraulics, Pilot hydraulics, Steering and Brake system		
3 Cooling fan and Brake system		
Electro-hydraulic servo controls	•	•
Electronic hydraulic lever lock	•	•
Automatic boom kick-out	•	•
Automatic bucket positioner	•	•
Double-acting hydraulic cylinders	•	•
Indicator glass for hydraulic oil level	•	•
Hydraulic oil cooler	•	•
<b>External equipment</b>		
Orange hand rails	•	•
Fenders, front and rear	•	•
Viscous cab mounts	•	•
Rubber engine and transmission mounts	•	•
Frame, joint lock	•	•
Vandalism lock prepared for		
Engine compartment	•	•
Radiator grille"		
Lifting eyes	•	•
Tie-down eyes	•	•
Fabricated counterweight	•	•
Counterweight, pre-drilled for optional guards	•	•

# Equipment.

## OPTIONAL EQUIPMENT

	L110H	L120H
<b>Service and maintenance</b>		
Automatic lubrication system	•	•
Automatic lubrication system for long boom	•	•
Grease nipple guards	•	•
Oil sampling valve	•	•
Refill pump for grease to lube system	•	•
Tool kit	•	•
Wheel nut wrench kit	•	•
CareTrack, GSM, GSM/Satellite	•	•
Telematics, Subscription	•	•
<b>Engine</b>		
Air pre-cleaner, cyclone type	•	•
Air pre-cleaner, oil-bath type	•	•
Air pre-cleaner, turbo type	•	•
Engine auto shutdown	•	•
Engine block heater 230V/110V	•	•
Fuel fill strainer	•	•
Fuel heater	•	•
Hand throttle control	•	•
Max. fan speed, hot climate	•	•
Radiator, corrosion-protected	•	•
Reversible cooling fan	•	•
Reversible cooling fan and axle oil cooler	•	•
<b>Electrical system</b>		
Anti-theft device	•	•
Emergency stop	•	•
Locking device, Tag out Lock out	•	•
Headlights, assym. left	•	•
License plate holder, lighting	•	•
Rear vision system, colour LCD monitor in the cab	•	•
Rear view mirrors, Long arm	•	•
Rear view mirrors, adjustable, el.heated, Long arm	•	•
Reduced function working lights, reverse gear activated	•	•
Reverse alarm, audible	•	•
Reverse alarm, audible, multi-frequency	•	•
Reverse warning light, strobe lighting	•	•
Shortened headlight support brackets	•	•
Side marker lamps	•	•
Warning beacon LED	•	•
Working lights halogen, attachments	•	•
Working lights LED, attachments	•	•
Working lights on cab halogen, front and rear	•	•
Working lights on cab halogen, rear	•	•
Working lights front, extra	•	•
LED Head Light	•	•
Working lights, on cab LED, front and rear	•	•
Working lights, on cab LED, rear	•	•
Working lights, rear in grille, 2 LED lamps	•	•
Working lights, front above head lamps, 2 LED lamps	•	•
Taillight, LED lamp	•	•
Electrical distribution unit 24 volt	•	•
Load Assist	•	•
Radar detect system	•	•
Jump start connector, NATO-Type	•	•

	L110H	L120H
<b>Cab</b>		
Anchorage for Operator's manual	•	•
Automatic Climate Control, ACC	•	•
ACC control panel, with Fahrenheit scale	•	•
Asbestos dust protection filter	•	•
Ashtray	•	•
Cab air pre-cleaner, cyclone type	•	•
Carbon filter	•	•
Cover plate, under cab	•	•
Lunch box holder	•	•
Volvo Armrest, operator's seat, left	•	•
Operator's seat, Volvo air susp, heavy-duty, high back, heated	•	•
Operator's seat, (air seat std) 2-point seat belt	•	•
Operator's seat, (air seat std) 3-point seat belt	•	•
Radio installation kit incl. 12 volt outlet, left side	•	•
Radio installation kit incl. 12 volt outlet, right side	•	•
Radio (with AUX, Bluetooth and USB connection)	•	•
Subwoofer	•	•
Steering wheel knob	•	•
Sun blinds, rear windows	•	•
Sun blinds, side windows	•	•
Timer cab heating	•	•
Window, sliding, door	•	•
Universal door/ignition key	•	•
Remote door opener	•	•
Forward view mirror	•	•
Cab heater power outlet 240V	•	•
<b>Drivetrain</b>		
OptiShift transmission with Lock-up RBB	•	•
Diff lock front 100%, Limited Slip rear	•	•
Speed limiter	•	•
Wheel/axle seal guards	•	•
<b>Brake system</b>		
Oil cooler and filter front & rear axle	•	•
Stainless steel, brake lines	•	•
<b>Hydraulic system</b>		
Boom suspension system	•	•
Separate attachment locking	•	•
Arctic kit, attachment locking hoses	•	•
Arctic kit, for 3rd function	•	•
Boom cylinder hose and tube guards	•	•
Hydraulic fluid, biodegradable, Volvo	•	•
Hydraulic fluid, fire-resistant	•	•
Hydraulic fluid, for hot climate	•	•
Hydraulic 3rd function	•	•
hydraulic 3rd-4th function	•	•
Hydraulic constant flow control with detent for 3rd function	•	•
Single lever control, hydraulics 2 functions	•	•
Single lever control, hydraulics 3 functions	•	•
Single lever control, hydraulics 4 functions	•	•

	L110H	L120H
<b>External equipment</b>		
Cab ladder, rubber-suspended	•	•
Deleted front mudguards & wideners rear	•	•
Fire suppression system	•	•
Mudguards, full cover, rear for 80-series tires	•	•
Mudguards, full cover, rear for 65-series tires	•	•
Long boom	•	•
Tow hitch	•	•
<b>Protective equipment</b>		
Belly guard front	•	•
Belly guard rear	•	•
Cover plate, heavy-duty, front frame	•	•
Cover plate, rear frame	•	•
Cover plate, front/rear axle	•	•
Cab roof, heavy-duty	•	•
Guards for front headlights	•	•
Guards for radiator grill	•	•
Guards for tail lights	•	•
Windows, side and rear guards	•	•
Windshield guard	•	•
Corrosion protection, painting of machine	•	•
Corrosion protection, painting of attachment bracket	•	•
Bucket Teeth protection	•	•

	L110H	L120H
<b>Other equipment</b>		
CE-marking	•	•
Comfort Drive Control (CDC)	•	•
Counterweight, logging	•	•
Counterweight, signal painted, chevrons	•	•
Secondary steering with automatic test function	•	•
Sound decal, EU	•	•
Sound decal, USA	•	•
Reflecting stickers (decals), machine contour	•	•
Reflecting stickers (stripes), machine contour Cab	•	•
Noise reduction kit, exterior	•	•
Sign, slow moving vehicle	•	•
Sign, 50 km/h	•	•
<b>Tires</b>		
23.5 R25	•	•
750/65 R25	•	•
<b>Attachments</b>		
Buckets:		
Rock straight or spade nose	•	•
General purpose	•	•
Re-handling	•	•
Light material	•	•
Wear parts:		
Bolt-on and weld-on bucket teeth	•	•
Segments	•	•
Cutting edge in three sections, bolt-on	•	•
Fork equipment	•	•
Material handling arm	•	•
Log grapples	•	•

### Selection of Volvo optional equipment

**Attachment bracket**



**Load Assist**



**White noise**



**Rotating beacon LED**



**Single lever control**



**Radar detect system**



Not all products are available in all markets. Under our policy of continuous improvement, we reserve the right to change specifications and design without prior notice. The illustrations do not necessarily show the standard version of the machine.

**VOLVO**

**Volvo Construction Equipment**  
[www.volvoce.com](http://www.volvoce.com)