



Volvo Construction Equipment

L250H

Volvo Wheel Loaders 33.4-39.0t (73,600-86,000lbs) 395hp



A passion for performance

At Volvo Construction Equipment, we're not just coming along for the ride. Developing products and services that raise productivity – we are confident we can lower costs and increase profits for customers around the globe. Part of the Volvo Group, we are passionate about innovative solutions to help you work smarter – not harder.

Helping you to do more

Doing more with less is a trademark of Volvo Construction Equipment. High productivity has long been married to low energy consumption, ease of use and durability. When it comes to lowering life-cycle costs, Volvo is in a class of its own.

Designed to fit your needs

There is a lot riding on creating solutions that are suited to the particular needs of different industry applications. Innovation often involves high technology – but it doesn't always have to. Some of our best ideas have been simple, based on a clear and deep understanding of our customers' working lives.



You learn a lot in 180 years

Over the years, Volvo has advanced solutions that have revolutionized the use of construction equipment. No other name speaks Safety louder than Volvo. Protecting operators, those around them and minimizing our environmental impact are traditional values that continue to shape our product design philosophy.

We're on your side

We back the Volvo brand with the best people. Volvo is truly a global enterprise, one that is on standby to support customers quickly and efficiently – wherever they are.

We have a passion for performance.

A strong, dedicated, capable dealer network.

Our dealers are strategically located throughout North America to provide the equipment you need and the parts and service support you demand for a productive and profitable operation.

The strength of our dealer network is enhanced with extensive individualized product support training at our best-in-class Customer Center in Shippensburg and through hands-on training. Using a great Product Demonstration Center featuring a dedicated area for most common applications, visitors operate equipment from our entire product line under a variety of simulated working conditions. This facility is in year-round use by our dealers and customers.

Building the best starts right here.

The products designed and manufactured by Volvo Construction Equipment have their beginnings at the most advanced Research & Design centers in the industry. Volvo CE machines are designed in 11 R&D centers and produced in 15 manufacturing facilities across the world.

The major R&D center and manufacturing plant in the Americas is located in Shippensburg, Pennsylvania. This facility has been in operation for over 30 years and – with its recently added 200,000 sq. ft. expansion – now covers 570,000 sq. ft. on an 80 acre campus. Dedicated work teams and highly advanced technologies and techniques using the Volvo Production System ensure continuous quality improvements, labor savings and cost control to reach the high quality that our customers have come to expect from Volvo.





Volvo Trucks



Renault Trucks



Mack Trucks



UD Trucks



Volvo Buses



Volvo Construction Equipment



Volvo Penta



Volvo Financial Services



OptiShift

Volvo's OptiShift technology combines the company's patented Reverse By Braking (RBB) technology and a torque converter with lock-up. Lock-up creates a direct drive between the engine and transmission – eliminating power losses in the torque converter and reducing fuel consumption by up to 18%.

An efficient operation

Innovation is at the core of Volvo Construction Equipment. That's why our engineers are developing clever innovations to make equipment more fuel efficient while reducing emissions and environmental impact. OptiShift technology – a unique technical advancement which reduces fuel consumption by up to 18% and increases performance in wheel loaders – is just one example of this.

Reverse By Braking (RBB)

The Volvo patented RBB function senses the loader's direction and slows the machine when the operator changes direction by applying the service brakes automatically. This increases fuel efficiency and improves operator comfort. RBB is ideal for short cycle or truck loading applications.



Intelligent hydraulics

Volvo's load-sensing hydraulics supply power to the hydraulic functions according to demand, lowering fuel consumption. The powerful system ensures fast response for shorter cycle times while delivering smooth operation through superior control of both the load and the attachment.



Eco pedal

Volvo's unique eco pedal applies mechanical push-back force when the accelerator is used excessively and engine rpm is about to exceed the economic operating range. This encourages the operator to ease off the throttle, reducing fuel consumption.

Fully loaded

The new L250H from Volvo is a high production machine designed to increase your productivity and profitability in applications including quarry, aggregates, mining and heavy infrastructure. Experience short cycle times, high breakout force and excellent controllability with this heavy-duty machine.

Z-bar linkage

Volvo's proven Z-bar linkage provides high breakout force for strong, powerful digging in hard materials. The high lift capacity enables fully loaded buckets to be elevated to maximum height. Fast hydraulic speeds deliver quick load cycles, increasing productivity even in the toughest environments.



Boom Suspension System

The optional Boom Suspension System (BSS) boosts productivity by up to 20% by absorbing shock and reducing the bouncing and bucket spillage that occurs when operating on rough ground. This enables faster and more comfortable work cycles and increases machine life.



Volvo bucket design

Volvo buckets are developed and built as an integrated part of Volvo wheel loaders. As a result, the two are perfectly matched and work in harmony as one solid, reliable unit to deliver maximum productivity and long life.



Powertrain

The ideally-matched, all-Volvo powertrain has been built to work together in perfect harmony. The Volvo design has been rigorously tested to deliver optimized performance, high productivity, low fuel consumption and superior reliability.

Heavy-duty for heavy duties

If you're looking for a strong, durable and reliable wheel loader to handle heavy-duty applications then look no further than the L250H. Powered by a premium Volvo Tier 4 Final/Stage IV engine, this robust machine provides the strength and reliability you need to optimize your operation.

Volvo engine

Featuring advanced technology and built on decades of experience, the powerful Volvo Tier 4 Final/Stage IV engine delivers high performance and low fuel consumption. During the regeneration process, particulate matter collected in the DPF is burnt off without interrupting operation, performance or productivity.



Reversible cooling fan

The hydraulically-driven, electronically controlled cooling fan regulates the temperature of the vital components. It automatically activates only when it's needed – reducing fuel consumption and noise. The optional reversible functionality – which blows air in the opposite direction – allows for self-cleaning of the cooling units.



Axle oil cooling

Both the front and the rear axle feature an axle oil circulation feature which allows the axle oil to flow inside the axle – this cools the oil.

Smart service access

At Volvo we know that on site, time means money. That's why the L250H is fitted with a tilting cab – a feature which significantly improves service and maintenance access to give you more uptime. This is just one example of the many time-saving features Volvo incorporates into its machines. Trust Volvo to maintain your uptime.

Maintenance-free batteries

Two heavy-duty, maintenance-free 12V batteries in series provide a 24V electrical system. The batteries are located in a well-sealed compartment on the right side of the machine.



Lubrication system

The optional, automatic lubrication system controls greasing when the machine is in operation, resulting in more uptime and reduced maintenance. The operator can alter the lubrication cycle to suit the application.



Maintaining a smooth operation

Enjoy peace-of-mind for maximum machine uptime with the rear axle design. The sealed oscillation pins cradle keeps the grease in and the dirt out, keeping components greased for up to 8,000 hours so you can rely on reduced overall service time and costs.



Engine access

Electrically activated, the wide-opening engine hood allows quick and easy service access to the engine and components for maximum uptime.



Tilting cab

The cab can be tilted in two positions – 35° and 70°. Tilting the cab greatly improves service and maintenance access which leads to more uptime and increased machine availability. The cab is tilted via a manually operated hydraulic pump.

Loaded with innovation



Volvo cab

Volvo's industry-leading, certified ROPS/FOPS cab features ergonomically placed controls, low internal noise levels, vibration protection and ample storage space.



OptiShift

Volvo's OptiShift technology reduces fuel consumption by up to 18%, increases operator comfort and reduces stress in the drivetrain.

Z-bar linkage

Volvo's proven Z-bar linkage provides high breakout force for strong, powerful loading in hard materials.



Volvo bucket design

Volvo buckets are perfectly matched to Volvo machines – together they work in harmony as one solid, reliable unit to deliver maximum productivity.

Boom Suspension System (BSS)

The BSS boosts productivity by up to 20% by absorbing shock and reducing the bouncing and bucket spillage that occurs when operating at speed on rough terrain.

Intelligent hydraulics

Volvo's load-sensing hydraulics supply power to the hydraulic functions according to demand, lowering fuel consumption.



Powertrain

The ideally-matched, all-Volvo powertrain has been built to work together in perfect harmony – ensuring optimized performance.

Diesel Exhaust Fluid (DEF)

Volvo offers a total DEF solution that is quality assured, cost efficient and easily accessible. Contact your Volvo dealer for more information.

Single lever

The optional, multi-functional joystick gives the operator simultaneous and precise control of the linkage and drive.

Volvo engine

Volvo's Tier 4 Final/Stage IV engine delivers high performance and low fuel consumption.

Easy service access

Electrically activated, wide-opening engine hood allows quick and easy service access to the engine compartment.



Tilting cab

The cab can be tilted in two positions – 30° and 70° – for improved service and maintenance access. This leads to more uptime and increased machine availability.





Volvo cab

The spacious ROPS/FOPS certified cab provides a comfortable operating environment with ergonomically placed controls and ample storage space. With low internal noise levels and vibration protection, operators will experience a productive work shift.

Comfort increases productivity

Spacious, comfortable, safe and quiet – those are just some of the words that describe Volvo's industry-leading cab. With ideally located controls, a comfortable seat and ample space for storage, it's no wonder that operators feel content and productive throughout the shift in a Volvo machine.

Visibility

Volvo offers a variety of options to improve safety and visibility when working in the dark. This includes reflectors which follow the contour of the machine, LED entrance lights which illuminate the cab for safe entry and exit and additional LED work lamps which increase visibility around the machine.



Cab air filter

The cab air intake is located high on the machine, where air is cleanest. The easy-to-replace pre-filter separates coarser dust and particles before the air passes through the main filter and finally enters the cab. Volvo's industry-leading design allows 90% of the cab air to be recirculated through the main filter for continuous dust removal.



Single lever control

For ease of operation, the optional, multi-functional joystick gives the operator simultaneous and precise control of the hydraulic functions.



PROFITABILITY



SERVICE PLAN

DAY01	DAY02	DAY03	DAY04	DAY05	DAY06	DAY07
						✓
			✓	✓		
	✓				✓	✓
		✓				
✓						
		✓				

FUEL CONSUMPTION



Customer Support Agreements

The range of Customer Support Agreements offer preventive maintenance, total repairs and a number of uptime services. Volvo uses the latest technology to monitor machine operation and status, giving you advice to increase your profitability. By having a Customer Support Agreement you are in control of your service costs.

Volvo L250H in detail

Engine

V-ACT Stage IV/Tier 4F 13 liter, 6-cylinder straight turbocharged diesel engine with 4 valves per cylinder, overhead camshaft and electronically controlled unit injectors. The engine has wet replaceable cylinder liners and replaceable valve guides and valve seats. The throttle applications is transmitted electrically from the throttle pedal or the optional hand throttle .

Air Cleaning 2 stages

Cooling system: Hydrostatic, electronically controlled fan and intercooler of the air-to-air type.

Engine	D13J		
Max power at	r/s (r/min)	25.0 (1 500)	
SAE J1995 gross	kW / hp	291 (395)	
ISO 9249, SAE J1349 net	kW / hp	290 (394)	
Max torque at	r/s (r/min)	18.3 (1 100)	
SAE J1995 gross	Nm lbf-ft	2 231	1,645
ISO 9249, SAE J1349 net	Nm lbf-ft	2 216	1,634
Economic working range	r/min	800 - 1600	
Displacement	l in ³	12.8	782

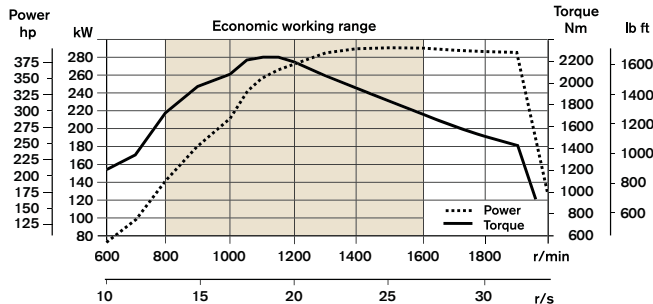

Brake system

Service brake: Volvo dual-circuit system . Outboard-mounted fully hydraulic operated, fully sealed oil circulation-cooled wet disc brakes.

Parking brake: Fully sealed, wet multi-disc brake built into the transmission. Applied by spring force, electro-hydraulic release .

Secondary brake: Dual brake circuits with rechargeable accumulators. One circuit or the parking brake fulfills all safety requirements.

Standard: The brake system complies with the requirements of ISO 3450.

Accumulators	l US gal	2 x 1.0 + 1 x 0.5	2 x 0.26 + 1 x 0.13
Number of brake discs per wheel (front)		1	

Electrical system

Central warning system: Contronic electrical system with central warning light and buzzer for following functions: - Serious engine fault - Low steering system pressure - Over speed warning engine - Interruption in communication (computer fault) Central warning light and buzzer with the gear engaged for the following functions. - Low engine oil pressure - High engine oil temperature - High charge air temperature - Low coolant level - High coolant temperature - High crank case pressure - Low transmission oil pressure - High transmission oil temperature - Low brake pressure - Engaged parking brake - Fault on brake charging - Low hydraulic oil level - High hydraulic oil temperature - Overspeeding in engaged gear - High brake cooling oil temperature front and rear axles.

Voltage	V	24
Batteries	V	2 x 12
Battery capacity	Ah	2 x 170
Cold cranking capacity, approx	A	1 000
Alternator rating	W/A	2 280 / 80
Starter motor output	kW	7

Drivetrain

Torque converter: Single-stage.

Transmission: Volvo countershaft transmission with Fast and smooth shifting of gears with Pulse Width Modulation (PWM) valve. Torque converter with lockup.

Transmission: Volvo Automatic Power Shift (APS) with fully automatic shifting 1-4 and mode selector with 4 different gear shifting programs.

Axles: Volvo fully floating axle shafts with planetary hub reductions and nodular iron axle housing. Fixed front axle and oscillating rear axle. 100% differential lock on the front axle.

Transmission	Volvo HTL307			
Torque multiplication, stall ratio	2,094:1			
Maximum speed, forward/reverse	1st gear	km/h	mph	7 4.3
	2nd gear	km/h	mph	11.5 7.1
	3rd gear	km/h	mph	24.5 15.2
	4th gear*	km/h	mph	38 23.6
Measured with tires	29,5R25 L4			
Front axle/rear axle	AWB 50B / 41			
Rear axle oscillation ±				° 15
Ground clearance at 15° osc.	mm	in	600	23.6

*) limited by ECU

Cab

Instrumentation: All important information is centrally located in the operator's field of vision. Display for Contronic monitoring system.

Heater and defroster: Heater coil with filtered fresh air and fan with auto and 11 speeds. Defroster vents for all window areas.

Operator's seat: Operator's seat with adjustable suspension and retractable seatbelt.

Standard: The cab is tested and approved according to ROPS (ISO 3471), FOPS (ISO 3449). The cab meets with requirements according to ISO 6055 (Operator overhead protection - Industrial trucks) and SAE J386 ("Operator Restraint System").

Sound level in cab according to ISO 6396/SAE J2105

LpA	dB(A)		70
-----	-------	--	----

External sound level according to ISO 6395/SAE J2104

LwA	dB(A)		109
-----	-------	--	-----

Ventilation	m ³ /min	yd ³ /min	9	11.8
-------------	---------------------	----------------------	---	------

Heating capacity	kW		16
------------------	----	--	----

Air conditioning (optional)	kW		7.5
-----------------------------	----	--	-----

Steering system

Steering system: Load-sensing, hydrostatic articulated steering.

System supply: The steering system has priority feed from a load-sensing axial piston pump with variable displacement.

Steering cylinders: Two double-acting cylinders.

Cylinder bore	mm	in	100	3.9
---------------	----	----	-----	-----

Piston rod diameter	mm	in	60	2.4
---------------------	----	----	----	-----

Stroke	mm	in	525	20.7
--------	----	----	-----	------

Working pressure	MPa	bar	21 ± 0.35	210 ± 3.5
------------------	-----	-----	-----------	-----------

Maximum flow	l/min	gal/min	202	53.4
--------------	-------	---------	-----	------

Maximum articulation	± °		37
----------------------	-----	--	----

Service

Service accessibility: Large, easy-to-open hood covering whole engine department, electrically operated. Fluid filters and component breather air filters promote long service intervals. Possibility to monitor, log and analyze data to facilitate troubleshooting.

Fuel Tank	l	gal	366	96.7
-----------	---	-----	-----	------

DEF Tank	l	gal	31	8.2
----------	---	-----	----	-----

Engine coolant	l	gal	55	14.5
----------------	---	-----	----	------

Hydraulic oil tank	l	gal	226	59.7
--------------------	---	-----	-----	------

Transmission oil	l	gal	48	12.7
------------------	---	-----	----	------

Engine oil	l	gal	50	13.2
------------	---	-----	----	------

Axle oil front/rear	l	gal	78 / 80	20.6 / 21.1
---------------------	---	-----	---------	-------------

Lift arm system

Z-bar			
Cylinders lift	2		
Cylinder bore	mm	190	7.5
Piston rod diameter	mm	100	3.9
Stroke	mm	873	34.4
Cylinder tilt	1		
Cylinder bore	mm	220	8.7
Piston rod diameter	mm	120	4.7
Stroke	mm	570	22.4

Hydraulic system

System supply: Two load-sensing axial piston pumps with variable displacement. The steering system always has priority.

Valves: Double-acting 2-spool valve. The main valve is controlled by a 2-spool pilot valve.

Lift function: The valve has three positions; raise, hold and lower position. Inductive/magnetic automatic boom kickout can be switched on and off and is adjustable to any position between maximum reach and full lifting height.

Tilt function: The valve has three functions including rollback, hold and dump. Inductive/magnetic automatic tilt can be adjusted to the desired bucket angle.

Cylinders: Double-acting cylinders for all functions.

Filter: Full flow filtration through 10 micron (absolute) filter cartridge.

Working pressure maximum, pump 1	MPa	bar	29.0 ± 0.5	290 ± 5
Flow	l/min	gal/min	252	66.6
at	MPa	bar	10	100
engine speed	r/s(r/min)		32 (1 900)	
Working pressure maximum, pump 2	MPa	bar	31.0 ± 0.5	310 ± 5
Flow	l/min	gal/min	202	53.4
at	MPa	bar	10	100
engine speed	r/s(r/min)		32 (1 900)	
Working pressure maximum, pump 3	MPa	bar	25.0 ± 0.5	250 ± 5
Flow	l/min	gal/min	83	21.9
at	MPa	bar	10	100
engine speed	r/s(r/min)		32 (1 900)	
Pilot system	MPa	bar	3.2 - 4.0	32 - 40
Cycle times				
Lift			s	7.1
Tilt			s	1.9
Lower, empty			s	4.1
Total cycle time			s	13.1

Specifications

Tires L250H: 29.5 R25 L4 (Tire deflection: Standard)

			Standard boom		Long boom	
A	mm	in	9 490	373.6	9 800	385.8
B	mm	in	7 530	296.5	7 800	307.1
C	mm	in	3 750	147.6	3 750	147.6
D	mm	in	540	21.3	540	21.3
E	mm	in	1 790	70.5	1 890	74.4
F	mm	in	3 740	147.2	3 730	146.9
F ₁	mm	in	3 630	142.9	3 630	142.9
F ₂	mm	in	2 850	112.2	2 840	111.8
G	mm	in	2 132	83.9	2 133	84.0
H	mm	in	3 140	123.6	3 490	137.4
J	mm	in	4 340	170.9	4 700	185.0
K	mm	in	4 640	182.7	5 000	196.9
L	mm	in	6 330	249.2	6 680	263.0
M	mm	in	1 670	65.7	1 640	64.6
N	mm	in	2 340	92.1	2 610	102.8
O	°			62		57
P ₂	°			45		45
P	°			47		47
R	°			41		43
R ₁	°			48		51
S	°			75		81
S ₁	°			42		46
T	mm	in	129	5.1	197	7.8
U*	mm	in	540	21.3	620	24.4
V	mm	in	3 580	140.9	3 580	140.9
X	mm	in	2 400	94.5	2 400	94.5
Y	mm	in	3 170	124.8	3 170	124.8
Z	mm	in	3 940	155.1	4 150	163.4
a ₁	mm	in	15 860	624.4	16 060	632.3
a ₂	mm	in	7 110	279.9	7 110	279.9
a ₃	mm	in	3 950	155.5	3 950	155.5
a ₄	°			37		37

* Carry position SAE



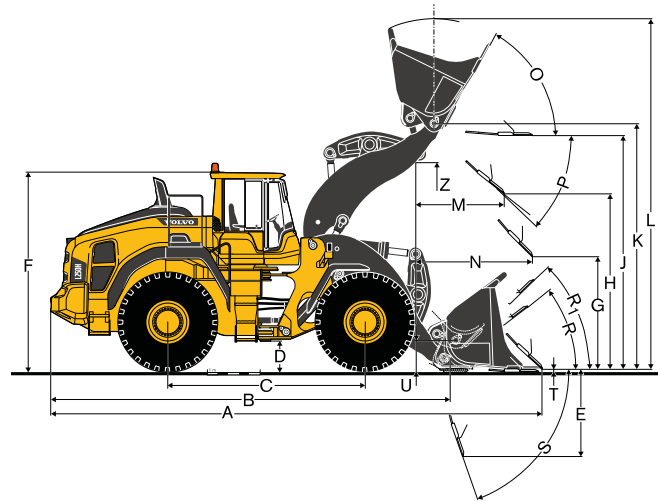



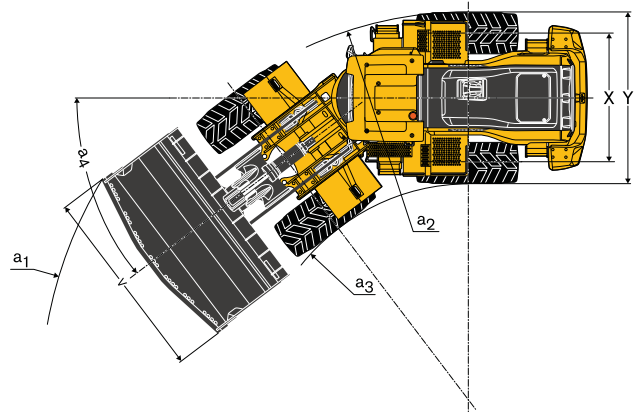



Bucket: 5.7 m³ (7.5 yd³) STE P T SEG



Where applicable, specifications and dimensions are according to ISO 7131, SAE J732, ISO 7546, SAE J742, ISO 14397, SAE J818.



L250H

Tires 29.5 R25 L4	REHANDLING				GENERAL PURPOSE				ROCK***				LIGHT MATERIAL		LONG BOOM*	
																
	6.1 m ³ (8.0 yd ³) STE P BOE	6.9 m ³ (9.0 yd ³) STE P BOE	5.7 m ³ (7.5 yd ³) STE P T SEG	6.4 m ³ (8.4 yd ³) STE P T SEG	6.4 m ³ (8.4 yd ³) STE P BOE	5.5 m ³ (7.2 yd ³) STE P T SEG	5.5 m ³ (7.2 yd ³) SPN P T SEG	6 m ³ (7.2 yd ³) SPN P T SEG	10.2 m ³ (13.3 yd ³) LM P							
Volume, heaped ISO/SAE	m ³ yd ³	6.1 8.0	6.9 9.0	5.7 7.5	6.4 8.4	6.4 8.4	5.5 7.2	5.5 7.2	6.0 7.8	10.2 13.3	-	-				
Volume at 110% fill factor	m ³ yd ³	6.7 8.8	7.6 9.9	6.3 8.2	7.0 9.2	7.0 9.2	6.1 8.0	6.1 8.0	6.6 8.6	11.2 14.6	-	-				
Static tipping load, straight	kg lb	27 590 60,826	27 260 60,098	25 640 56,527	25 370 55,931	25 601 56,441	26 310 58,004	25 790 56,857	25 350 55,887	24 680 54,410	-3 050	-6,724				
at 35° turn	kg lb	24 520 54,057	24 200 53,352	22 760 50,177	22 500 49,604	22 733 50,118	23 390 51,566	22 860 50,398	22 440 49,472	21 810 48,083	-2 760	-6,085				
at full turn	kg lb	24 170 53,286	23 860 52,602	22 440 49,472	22 180 48,899	22 406 49,398	23 060 50,839	22 530 49,670	22 110 48,744	21 490 47,377	-2 740	-6,041				
Breakout force	kN lbf	311.8 70,095	291.0 65,419	323.4 72,703	298.7 67,150	303.9 68,319	330.9 74,389	277.1 62,295	265.2 59,619	251.9 56,629	-28	-6,295				
A	mm in	9 230 363.4	9 350 368.1	9 490 373.6	9 600 378.0	9 280 365.4	9 410 370.5	9 740 383.5	9 840 387.4	9 610 378.3	310	12.2				
E	mm in	1 560 61.4	1 670 65.7	1 790 70.5	1 890 74.4	1 600 63.0	1 710 67.3	2 020 79.5	2 110 83.1	1 930 76.0	100	3.9				
H**)	mm in	3 320 130.7	3 230 127.2	3 140 123.6	3 060 120.5	3 280 129.1	3 200 126.0	2 980 117.3	2 910 114.6	3 010 118.5	350	13.8				
L	mm in	6 490 255.5	6 610 260.2	6 330 249.2	6 440 253.5	6 440 253.5	6 680 263.0	6 680 263.0	6 740 265.4	7 030 276.8	350	13.8				
M**)	mm in	1 520 59.8	1 610 63.4	1 670 65.7	1 750 68.9	1 550 61.0	1 620 63.8	1 860 73.2	1 930 76.0	1 770 69.7	-30	-1.2				
N**)	mm in	2 270 89.4	2 320 91.3	2 340 92.1	2 390 94.1	2 290 90.2	2 320 91.3	2 460 96.9	2 490 98.0	2 390 94.1	270	10.6				
V	mm in	3 580 140.9	3 580 140.9	3 580 140.9	3 580 140.9	3 580 140.9	3 580 140.9	3 580 140.9	3 580 140.9	3 580 140.9	-	-				
a, clearance circle	mm in	15 740 619.7	15 800 622.0	15 860 624.4	15 910 626.4	15 760 620.5	15 830 623.2	16 000 629.9	16 040 631.5	16 060 632.3	-	-				
Operating weight	kg lb	34 560 76,192	34 720 76,544	33 980 74,913	34 120 75,222	33 970 74,891	34 900 76,941	35 280 77,779	35 250 77,713	34 790 76,699	-80	-176				

*) Measured with 5.7 m³ (7.5 yd³) GP STE P T SEG bucket

Note: This only applies to genuine Volvo attachments.

***) Measured to the tip of the bucket teeth or bolt-on edge.

Dump height to bucket edge measured at 45° dump angle. (Spade nose buckets at 42°.)

*) Measured with 29.5 R25 L5 tire

Bucket Selection Chart

The volume handled varies with the bucket fill and is often greater than indicated by the bucket's ISO/SAE volume. The table shows optimum bucket choice with regard to the material density.

Material	Bucket fill, %	Material density, t/m ³	Material density, lb/yd ³
Earth	110 - 115	1.4 - 1.6	2,360 - 2,697
Clay	110 - 120	1.4 - 1.6	2,360 - 2,697
Sand	100 - 110	1.6 - 1.9	2,697 - 3,203
Gravel	100 - 110	1.7 - 1.9	2,865 - 3,203
Rock	75 - 100	1.5 - 1.9	2,528 - 3,203

The size of rock buckets is optimized for optimal penetration and filling capability rather than the density of the material.

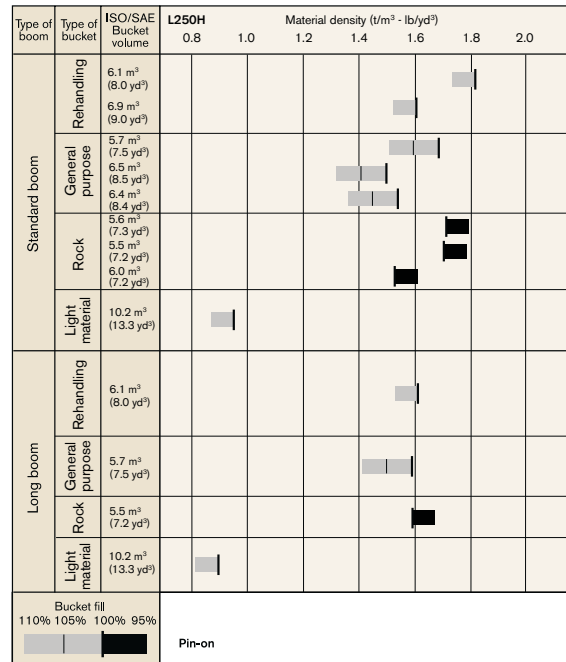

Supplemental Operating Data

Tires 29.5 R25 L4	Standard boom				Long boom			
	29.5 R25 L5		875/65R29 L3		29.5 R25 L5		875/65R29 L3	
Width over tires	mm in	35 1.4	95 3.7	35 1.4	95 3.7			
Ground clearance	mm in	40 1.6	-10 -0.4	40 1.6	-20 -0.8			
Tipping load, full turn	kg lb	1 010 2,227	180 397	930 2,050	180 397			
Operating weight	kg lb	1 490 3,284	650 1,433	1 500 3,307	650 1,433			

Equipment

STANDARD EQUIPMENT

Service and maintenance

Engine oil remote drain and fill
Transmission oil remote drain and fill
Lubrication manifolds, ground accessible
Pressure check connections: transmission and hydraulic, quick-connects
Tool box, lockable

Engine

Exhaust after-treatment system
Two stage air cleaner, pre-cleaner, primary and secondary filter
Indicator for coolant level
Preheating of induction air
Fuel pre-filter with water trap
Fuel filter
Crankcase breather oil trap
Exterior radiator air intake protection

Electrical system

24 V, pre-wired for optional accessories
Alternator 24V/80A/2280W
Battery disconnect switch
Fuel gauge
Hour meter
Electric horn
Instrument cluster:
Fuel level
Diesel Exhaust Fluid/AdBlue level
Transmission temperature
Coolant temperature
Instrument lighting

Lighting:

Twin halogen front headlights with high and low beams
Parking lights
Double brake and tail lights
Turn signals with flashing hazard light function
Halogen work lights (2 front and 2 rear)

Contronic monitoring system

Monitoring and logging of machine data
Contronic display
Fuel consumption
Diesel Exhaust Fluid/AdBlue consumption
Ambient temperature
Clock
Test function for warning and indicator lights
Brake test
Test function, sound level at max fan speed

Warning and indicator lights:

Battery charging
Parking brake
Warning and display message:
Regeneration
Engine coolant temperature
Charge-air temperature
Engine oil temperature
Engine oil pressure
Transmission oil temperature
Transmission oil pressure
Hydraulic oil temperature
Brake pressure
Parking brake applied
Brake charging
Overspeed at direction change
Axle oil temperature
Steering pressure
Crankcase pressure
Attachment lock open
Safety Belt Warning

Level warnings:

Fuel level
Diesel Exhaust Fluid/AdBlue level
Engine oil level
Engine coolant level
Transmission oil level
Hydraulic oil level
Washer fluid level

Contronic monitoring system

Engine torque reduction in case of malfunction indication:
High engine coolant temperature
High engine oil temperature
Low engine oil pressure
High crankcase pressure
High charge-air temperature

Engine shutdown to idle in case of malfunction indication:

High transmission oil temperature
Slip in transmission clutches

Keypad, background lit

Start interlock when gear is engaged

Drivetrain

Automatic Power Shift
Fully automatic gearshifting, 1-4
PWM-controlled gearshifting
Forward and reverse switch by hydraulic lever console

Indicator glass for transmission oil level

Differentials: Front, 100% hydraulic diff lock. Rear, conventional.

OptiShift

Lock-up first gear

Brake system

Dual brake circuits
Dual brake pedals
Secondary brake system
Parking brake, electro-hydraulic
Brake wear indicators

Cab

ROPS (ISO 3471), FOPS (ISO 3449)
Single key kit door/start
Acoustic inner lining
Cigarette lighter, 24 V power outlet
Lockable door
Cab heating with fresh air inlet and defroster
Fresh air inlet with two filters
Automatic heat control
Floor mat
Dual interior lights
Interior rear-view mirrors
Dual exterior rear-view mirrors
Sliding window, right side
Tinted windshield glass
Retractable seatbelt (SAE J386)
Adjustable steering wheel
Storage compartment
Document pocket
Sun visor
Beverage holder
Windshield washer front and rear
Windshield wipers front and rear
Interval function for front and rear wipers

Hydraulic system

Main valve, double acting 2-spool with hydraulic pilots
Variable displacement axial piston pumps (3) for:
1 Working hydraulics, Pilot hydraulics and Brake system
2 Working hydraulics, Pilot hydraulics, Steering and Brake system
3 Cooling fan and Brake system
Electro-hydraulic servo controls
Electronic hydraulic lever lock
Automatic boom kick-out
Automatic bucket positioner
Double-acting hydraulic cylinders
Indicator glass for hydraulic oil level
Hydraulic oil cooler

External equipment

Orange hand rails
Fenders, front and rear
Viscous cab mounts
Rubber engine and transmission mounts
Frame, joint lock
Vandalism lock prepared for
Engine compartment
Radiator grille
Lifting eyes
Tie-down eyes
Fabricated counterweight
Counterweight, pre-drilled for optional guards

OPTIONAL EQUIPMENT

Service and maintenance

Automatic lubrication system
Automatic lubrication system for long boom
Grease nipple guards
Oil sampling valve
Refill pump for grease to lube system
Tool kit
Wheel nut wrench kit
CareTrack, GSM, GSM/Satellite
Telematics, Subscription

Engine

Air pre-cleaner, cyclone type
Air pre-cleaner, oil-bath type
Air pre-cleaner, turbo type
Engine auto shutdown
Engine block heater 230V/110V
Fuel fill strainer
Fuel heater
Hand throttle control
Max. fan speed, hot climate
Radiator, corrosion-protected
Reversible cooling fan
Reversible cooling fan and axle oil cooler

Electrical system

Anti-theft device
Emergency stop
Locking device, Tag out Lock out
Headlights, assym. left
License plate holder, lighting
Rear vision system, colour LCD monitor in the cab
Rear view mirrors, Long arm
Rear view mirrors, adjustable, el.heated, Long arm
Reduced function working lights, reverse gear activated
Reverse alarm, audible
Reverse alarm, audible, multi-frequency
Reverse warning light, strobe lighting
Shortened headlight support brackets
Side marker lamps
Warning beacon LED
Working lights halogen, attachments
Working lights LED, attachments
Working lights on cab halogen, front and rear
Working lights on cab halogen, rear

OPTIONAL EQUIPMENT

Electrical system

LED Head Light
Working lights, on cab LED, front and rear
Working lights, on cab LED, rear
Working lights, rear in grille, 2 LED lamps
Working lights, front above head lamps, 2 LED lamps
Taillight, LED lamp
Electrical distribution unit 24 volt
Load Assist
Radar detect system
Jump start connector, NATO-Type

Cab

Anchorage for Operator's manual
Automatic Climate Control, ACC
ACC control panel, with Fahrenheit scale
Asbestos dust protection filter
Ashtray
Cab air pre-cleaner, cyclone type
Carbon filter
Cover plate, under cab
Lunch box holder
Volvo Armrest, operator's seat, left
Operator's seat, Volvo air susp, heavy-duty, high back, heated
Operator's seat, (air seat std) 2-point seat belt
Operator's seat, (air seat std) 3-point seat belt
Radio installation kit incl. 12 volt outlet, left side
Radio installation kit incl. 12 volt outlet, right side
"Radio (with AUX, Bluetooth and USB connection)"
Subwoofer
Steering wheel knob
Sun blinds, rear windows
Sun blinds, side windows
Timer cab heating
Window, sliding, door
Universal door/ignition key
Remote door opener
Forward view mirror
Cab heater power outlet 240V

Drivetrain

OptiShift transmission with Lock-up RBB
Diff lock front 100%, Limited Slip rear
Speed limiter
Wheel/axle seal guards

Brake system

Oil cooler and filter front & rear axle
Stainless steel, brake lines

Hydraulic system

Boom suspension system
Separate attachment locking
Arctic kit, attachment locking hoses
Arctic kit, for 3rd function
Boom cylinder hose and tube guards
Hydraulic fluid, biodegradable, Volvo
Hydraulic fluid, fire-resistant
Hydraulic fluid, for hot climate
Hydraulic 3rd function
hydraulic 3rd-4th function
Hydraulic Constant Flow Control with detent for 3rd function
Single lever control, hydraulics 2 functions
Single lever control, hydraulics 3 functions
Single lever control, hydraulics 4 functions

External equipment

Cab ladder, rubber-suspended
Deleted front mudguards
Fire suppression system
Mudguards, full cover, front and rear for 80-series tires
Mudguards, full cover, front and rear for 65-series tires
Mudguards, full cover wideners and prot. Included
Long boom
Tow hitch

Protective equipment

Belly guard front
Belly guard rear
Cover plate, heavy-duty, front frame
Cover plate, rear frame
Cover plate, front/rear axle
Cab roof, heavy-duty
Guards for front headlights
Guards for radiator grill
Guards for tail lights
Windows, side and rear guards
Windshield guard
Corrosion protection, painting of machine
Corrosion protection, painting of attachment bracket
Bucket Teeth protection

Other equipment

CE-marking
Comfort Drive Control (CDC)
Counterweight, logging
Counterweight, signal painted, chevrons
Secondary steering with automatic test function
Sound decal, EU
Sound decal, USA
Reflecting stickers (decals), machine contour
Reflecting stickers (stripes), machine contour Cab
Noise reduction kit, exterior
Sign, slow moving vehicle
Sign, 50 km/h

Tires

26.5 R25
775/65 R29
29.5 R25
875/65 R29

Attachments

Buckets:
Rock straight or spade nose
General purpose
Re-handling
Side-dump
Light material
Wear parts:
Bolt-on and weld-on bucket teeth
Segments
Cutting edge in three sections, bolt-on
Fork equipment
Material handling arm
Log grapples

SELECTION OF VOLVO OPTIONAL EQUIPMENT

Long boom



Load Assist



Fire suppression system



Comfort Drive Control



Single lever control



Radar detect system



Not all products are available in all markets. Under our policy of continuous improvement, we reserve the right to change specifications and design without prior notice. The illustrations do not necessarily show the standard version of the machine.

VOLVO

Volvo Construction Equipment

www.volvoce.com