



Volvo Construction Equipment

# L20H, L25H

Volvo Compact Wheel Loaders 4.5-4.9 t / 9,880-10,850 lb 64 hp



# A passion for performance

At Volvo Construction Equipment, we're not just coming along for the ride. Developing products and services that raise productivity – we are confident we can lower costs and increase profits for customers around the globe. Part of the Volvo Group, we are passionate about innovative solutions to help you work smarter – not harder.

## Helping you to do more

Doing more with less is a trademark of Volvo Construction Equipment. High productivity has long been married to low energy consumption, ease of use and durability. When it comes to lowering life-cycle costs, Volvo is in a class of its own.

## Designed to fit your needs

There is a lot riding on creating solutions that are suited to the particular needs of different industry applications. Innovation often involves high technology – but it doesn't always have to. Some of our best ideas have been simple, based on a clear and deep understanding of our customers' working lives.



## You learn a lot in 180 years

Over the years, Volvo has advanced solutions that have revolutionized the use of construction equipment. No other name speaks Safety louder than Volvo. Protecting operators, those around them and minimizing our environmental impact are traditional values that continue to shape our product design philosophy.

## We're on your side

We back the Volvo brand with the best people. Volvo is truly a global enterprise, one that is on standby to support customers quickly and efficiently – wherever they are.

## We have a passion for performance.

### A strong, dedicated, capable dealer network

Our dealers are strategically located throughout North America to provide the equipment you need and the parts and service support you demand for a productive and profitable operation.

The strength of our dealer network is enhanced with extensive individualized product support training at our best-in-class Customer Center in Shippensburg and through hands-on training. Using a great Product Demonstration Center featuring a dedicated area for most common applications, visitors operate equipment from our entire product line under a variety of simulated working conditions. This facility is in year-round use by our dealers and customers.

## Building the best starts right here.

The products designed and manufactured by Volvo Construction Equipment have their beginnings at the most advanced Research & Design centers in the industry. Volvo CE machines are designed in 11 R&D centers and produced in 15 manufacturing facilities across the world.

The major R&D center and manufacturing plant in the Americas is located in Shippensburg, Pennsylvania. This facility has been in operation for over 30 years and – with its recently added 200,000 sq. ft. expansion – now covers 570,000 sq. ft. on an 80 acre campus. Dedicated work teams and highly advanced technologies and techniques using the Volvo Production System ensure continuous quality improvements, labor savings and cost control to reach the high quality that our customers have come to expect from Volvo.





Volvo Trucks



Renault Trucks



Mack Trucks



UD Trucks



Volvo Buses



Volvo Construction Equipment



Volvo Penta



Volvo Financial Services

# Improve your efficiency

One of the keys to profitability is efficiency. Get the job done better and faster with the L20H and L25H. Bringing you quality as standard, all-around visibility and excellent stability, Volvo compact wheel loaders are the perfect partner for efficient performance.

## Tackle uneven terrains

Looking for excellent traction and stability on rough terrains? The L20H and L25H feature a  $38^{\circ} \pm 10^{\circ}$  articulated oscillating joint as well as 100% differential locks on both axles, activated by the operator.



## Access tight areas

Navigate safely in the confined spaces on your jobsite, thanks to the compact design of the L20H and L25H. Standing at a height of no more than 2500 mm (98.5 inches), featuring a rounded hood, transversally mounted engine and 8210 mm (323 inches) turning radius, the machines deliver excellent manoeuvrability.



## More comfort to get more done

Enjoy all-around visibility and easy operation from the comfort of the Volvo cab. A single joystick lever, incorporating lift/tilt auxiliary functions, offers operation of hydraulic attachments such as multi-purpose buckets, sweepers and augers. Combined with the flow sharing valve, which allows lift and tilt corrections while the hydraulic attachment is operating, gets the job done quicker.



## Designed with safety in mind

Get in and out the FOPS/ROPS certified cab easily, with a highly visible step that stands out against the surroundings. For ultimate control, the machines are fitted with a single inching brake pedal, allowing for operation at "creep speed" while using attachments such as a sweeper or snow blower. The large spacious cab features a high capacity cab air filter allowing a dust free working environment in tough applications.





# POWER TO PERFORM

Improve your cycle times with the fully automatic two-speed range hydrostatic drive, and work at a speed of up to 30 km/h (18.6 mph). The L20H and L25H are powered by a powerful turbo charged engine – with diesel oxidation catalyst (DOC) – meeting the latest emission regulations, without the need for regeneration or additives. Trust your Volvo to keep performance high and downtime low.



# ALL-AROUND COMPACT LOADER

We offer a wide range of attachments to make your L20H and L25H a true all-around compact loader. Perfectly matched to the machine's linkage system, hydraulics and driveline, Volvo attachments offer superior productivity and safety. For demanding attachments, Volvo offers optional high flow hydraulics, delivering up to 110 l/min @ 200 bar (29 gpm @ 2,900 psi).

# On to the next performance

To ensure your business runs smoothly, Volvo invests in the intelligent engineering of all machines – but we don't stop there. As your partner in production, we support what you do with the best equipment for the job. Our portfolio of attachments and services is designed to complement your machine's performance and boost your profitability.

## Small machine with big potential

Small in size but high in reach and dump height, the L20H and L25H are a great match for extreme truck loading operations.



## Less service, more work

Keep downtime to a minimum with maintenance points located at ground level and long service intervals – 100 hours for greasing and 500 hours for engine oil change. The compact wheel loaders are built using the best-in-class components for increased longevity and great value for money.



## Here to support you

We stand ready to respond to your every need. Maintain productivity and machine uptime with our range of Genuine Volvo Parts – all backed by Volvo warranty, with 24-hour parts delivery guarantee. Here with the complete solution, we'll help you stay on track, offering flexible maintenance and repair options to extend the life of your L20H and L25H.



## ActiveCare Direct

Maximize machine uptime and reduce repair costs with ActiveCare Direct. The intelligent service provides round the clock machine monitoring, as well as customer reports – to help take predictive and preventative maintenance actions.



# Fully loaded

## ALL-AROUND COMPACT LOADER

Volvo attachments are perfectly matched to the machine's linkage, hydraulics and driveline to increase productivity.

### Here to support you

Keep your machine in fighting form, with a range of Genuine Volvo Parts, as well as maintenance and repair plans.

## POWER TO PERFORM

Travel up to 30 km/h (18.6 mph) with the fully automatic two-speed range hydrostatic drive and powerful engine - with diesel oxidation catalyst.



### Maximize attachments use

For increased productivity and versatility, Volvo offers two options: a Universal Attachment Bracket that picks up most SSL/CTL attachments, or Volvo Attachment Bracket for use with Volvo Attachments.

### ActiveCare Direct

Maximize machine uptime and reduce repair costs with our ActiveCare Direct service, providing around the clock machine monitoring.



### Tackle uneven terrains

Increase traction on unstable ground, the L20H and L25H feature a  $38^{\circ} \pm 10^{\circ}$  articulated oscillating joint and operator controlled 100% differential locks on both axles.

### More comfort to get more done

Enjoy all-around visibility and easy operation. The Volvo cab features a single joystick lever that incorporates three functions, with flow sharing valve.

### Access tight areas

The compact design of the L20H and L25H, with a compact turning radius, allows for manoeuvrability in confined spaces.

### Designed with safety in mind

The FOPS/ROPS certified Volvo cab is equipped with a high capacity air filter and a highly visible entrance step and single inching brake pedal.

### Small machine with big potential

Small in size but high in reach and dump height, the L20H and L25H offers excellent loading capabilities.

### Less service, more work

Keep downtime to a minimum, with ground level greasing points, best-in-class components and long service intervals.

# Volvo L20H, L25H in detail

## Engine

The 4-cylinder Volvo common rail diesel engine is turbo charged, water-cooled, and compliant to EU Stage IIIB and EPA Tier 4 Final environmental regulations. An exhaust after treatment system and a Diesel Oxidation Catalyst are used. The engine is designed for high-performance cooling, facilitated by a main water-gallery and water passages between the cylinder bores. A Center Direct Injection System works as the combustion system, which provides increased injection pressure and a redesigned combustion chamber. The result is a 25% reduction of particles, which lowers the engine vibrations and radiated sound, and the total noise level.

		L20H	L25H
Engine	Volvo	D2.6M	D2.6M
Max power at	r/min (r/s)	2,400 (40)	2,400 (40)
SAE J1995 gross	kW (hp)	48 (64.4)	48 (64.4)
SAE J1349, ISO 9249 net	kW (hp)	47.3 (63.4)	47.3 (63.4)
Max. torque at	r/min (r/s)	1,500 (25)	1,500 (25)
SAE J1995 gross	Nm (ft lbf)	225 (166)	225 (166)
SAE J1349, ISO 9249 net	Nm (ft lbf)	221.6 (163.4)	221 (163)
Economic working range	r/min (r/s)	1,500 (25)	1,500 (25)
Displacement	l (in <sup>3</sup> )	2.62 (160)	2.62 (160)
Bore	mm (in)	87 (3.42)	87 (3.42)
Stroke	mm (in)	110 (6,712)	110 (6,712)

## Electrical system

Contronic electrical system with central warning light and buzzer, providing clear and easy to read information to the operator. A keypad allows easy navigation on the central LCD display with main and sub information field. Indicators and activation lights are available for various control and monitoring functions. An audible warning alarm will sound and a central warning indicator will flash if abnormal operating values or error messages arise. Gauges control coolant temperature and fuel level. A fuse test port is available in the fuse box, allowing operators to perform initial troubleshooting, reducing diagnostic time.

		L20H	L25H
Voltage	V	12	12
Batteries	V	12	12
Battery capacity	Ah	100	100
Alternator rating	W/A	70	70
Starter motor output	kW	2.5	2.5

## Drivetrain

The hydrostatic transmission allows a four-speed range change without tractive power interruption. Maximum tractive power is available in all speed ranges, regardless of the driving direction. The single 'inch brake pedal' offers variable machine speed control and a smooth transfer of power to the wheels, while maintaining a constant engine rpm. Using the single multifunctional right joystick, easily reach the transmission's forward, neutral, reverse and differential locks buttons. The machine is designed for single-handed operation, providing the operator with excellent ergonomics and greater efficiency in all applications. Two rigid planetary axles provide durability. The central articulating-oscillating joint and all-wheel drive deliver excellent mobility across all ground conditions. The 100% differential lock on both axles ensures minimal tire wear when operating on hard ground and maximum traction force in soft terrain.

		L20H	L25H
Angle of oscillation	± °	10	10
Oscillation at wheel, max.	mm (in)	226 (8.9)	245 (9.6)
Track	mm (in)	1,300 (51.2)	1,410 (55.5)
High-speed version			
1st gear	km/h (mi/h)	7 (4.3)	7 (4.3)
2nd gear	km/h (mi/h)	30 (18.6)	30 (18.6)

## Brake System

The reliable dual service brake applies to all four wheels: 1. Wear-free hydrostatic inching brake. 2. Central disc brake, actuated via the 'inch/brake pedal'. The first stage of the pedal application actuates the inching facility; the last third of pedal application applies the central disc brake. The independent, mechanically operated parking brake activates a central disc brake, which applies to all four wheels.

## Steering System

The steering unit is designed in an open center system for high axial loads and high travel speeds. It has no mechanical connection between the steering unit and the articulating/oscillating joint. As a result, the external forces that affect the steering cylinder are absorbed without disrupting the driver's focus. Any reaction forces are absorbed via the steering wheel. Thanks to the dual hydraulic pumps, the speed of the working hydraulic (lifting/tilting) system is not influenced by the steering system.

		L20H	L25H
Steering cylinders		1	1
Working pressure	MPa (psi)	21 (3,046)	21 (3,046)
Maximum flow	l/min (gal/min)	30 (7.93)	30 (7.93)
Max articulation	± °	38	38

## Cab

The cab is tested and approved according to ROPS (ISO 3471, SAE J1040) and FOPS (ISO 3449) specifications. The cab is compliant with ISO 6055 requirements for operator overhead protection. The cab is also compliant with industrial trucks and SAE J386 regarding Operator Restraint System. The operator seat features adjustable suspension and a retractable seatbelt. Fresh air is filtered through large elements prior entering the cab, ensuring clean air distribution in the cab. Several air vents enable fast de-misting and defrosting. The conronic monitoring system provides important information and is located in a central position to ensure all machine controls are within the operator's field of vision.

## Hydraulic system

Working hydraulics system with mechanical operated control valves. **System supplies:** a gear pump provides flow to the working hydraulics. **System control:** double-acting 3-spool main control valve. **The lift function has four positions:** lift, hold (neutral), lower and float. **The tilt function has three positions:** rollback, hold and dump. A fourth hydraulic function is available as an option to power the hydraulic implements (Hi-Tip bucket, angle sweeper, etc...) **Filtration:** full-flow filtration through 10 micron (absolute) filter cartridge in a combined suction-return-filter. **Cooling:** thermostatically controlled oil flow to the oil cooler (fast warm-up, optimized cooling).

		L20H	L25H
Main Flow	l/min (gal/min)	55.6 (14.5)	55.6 (14.5)
Working pressure max	bar (psi)	200 (2,900)	230 (3,335)
at engine speed	r/min (r/s)	2,400 (40)	2,400 (40)
Flow auxiliary hydraulics	l/min (gal/min)	55.6 (14.5)	55.6 (14.5)
Working pressure max	bar (psi)	175 (2,540)	175 (2,450)
at engine speed	r/min (r/s)	2,400 (40)	2,400 (40)
High Flow	l/min (gal/min)	110 (29)	110 (29)
Working pressure max	bar (psi)	200 (2,900)	200 (2,900)
at engine speed	r/min (r/s)	2,400 (40)	2,400 (40)

## Linkage

The parallel linkage system offers 100% parallel lift with the loading fork. The linkage system and the attachment bracket are designed for an excellent visibility to the front attachment and fork tines. The Volvo Attachment Bracket design has long guide pins and an additional sealing ring for protection against dust and mud.

		L20H	L25H
Linkage system		Parallel Linkage System	Parallel Linkage System
Lift cylinders		1	1
Tilt cylinders		1	1
Lift time (loaded)	s	5.2	5.2
Lowering time (empty)	s	3	3

## Service Refill

The wide opening engine hood provides fast and easy service access. The redesigned counterweight features a service opening on the left side, offering excellent service access to the hydraulic pumps. The main fuse box and control valve are located behind the right-hand side hood. This service panel is locked with a key.

		L20H	L25H
Fuel tank	l (gal)	60 (15.8)	60 (15.8)
Engine oil	l (gal)	10.2 (2.7)	10.2 (2.7)
Engine coolant	l (gal)	9.3 (2.4)	9.3 (2.4)
Hydraulic tank	l (gal)	59 (15.6)	59 (15.6)
Front axle oil	l (gal)	4.1 (1.1)	4.1 (1.1)
Rear axle oil	l (gal)	5.4 (1.4)	5.4 (1.4)

## Tires

		L20H	L25H
Size		335/80R18	335/80R18
Rim		11 x 18	11 x 18

## Sound Level

		L20H	L25H
Sound level in cab according to ISO 6396			
LpA	dB(A)	75	75
External sound level according to ISO 6395			
LwA	dB(A)	99	99

# Specifications

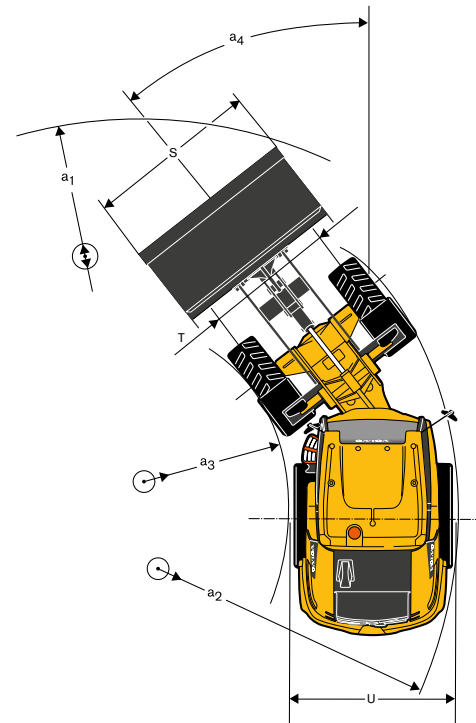
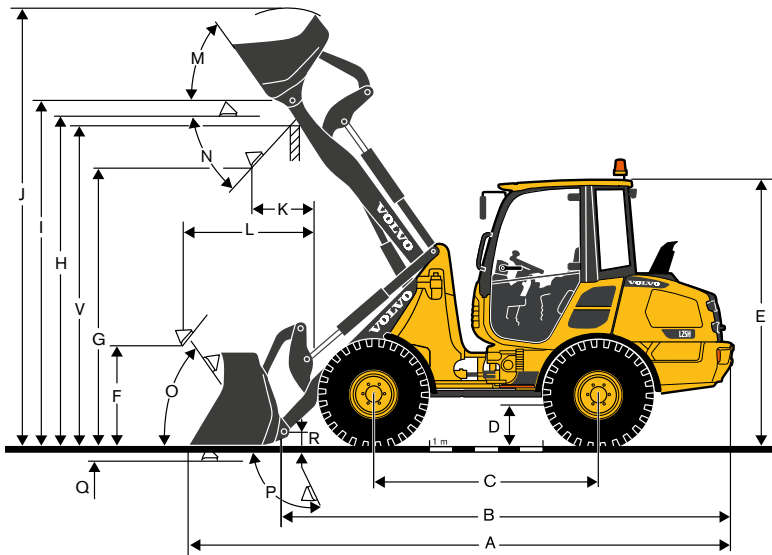

## SPECIFICATIONS ACCORDING TO BUCKET TYPE

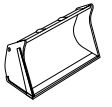
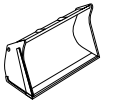
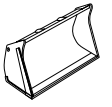
Description	Unit		L20H					
			General Purpose			Light Material		
with SSL attachment bracket & 405/70 R18 tires								
	Capacity heaped	m <sup>3</sup> yd <sup>3</sup>	0.6	0.78	0.8	1.05	.95	1.24
	Material density	kg/m <sup>3</sup> lb/yd <sup>3</sup>	2200	3,708	1700	2,865	1400	2,360
Static tipping load, straight (ISO / DIS)	kg lb	3400	7,496	3300	7,275	3200	7,055	
Static tipping load, full turn 38° (ISO / DIS)	kg lb	3000	6,614	2900	6,393	2850	6,283	
Hydraulic lifting capacity, max.	kN lbf	34	7,644	33	7,419	32	7,194	
Breakout force	kN lbf	31	6,969	27	6,070	24	5,395	
A Total length	mm ft in	5070	16'8"	5170	17'0"	5270	17'3"	
J Lift height, max.	mm ft in	4125	13'6"	4190	13'9"	4265	14'0"	
S Bucket width	mm ft in	1650	5'5"	1800	5'11"	1800	5'11"	
a <sub>1</sub> Clearance circle	mm ft in	8365	27'5"	8420	27'7"	8475	27'10"	
Q Digging depth	mm ft in	85	0'3"	85	0'3"	85	0'3"	
G Dump height	mm ft in	2495	8'2"	2415	7'11"	2340	7'8"	
K Reach at max. height	mm ft in	730	2'5"	785	2'7"	850	2'9"	
L Reach, max.	mm ft in	1545	5'1"	1605	5'3"	1670	5'6"	
Operating weight	kg lb	4600	10,141	4650	10,251	4700	10,362	

## DIMENSIONS

L20H parallel linkage with 405/70 R18 tires and SSL attachment bracket

Description	Unit			
	mm	ft in		
B	4275	14'0"		
C	2050	6'9"		
D	290	0'11"		
E	2485	8'2"		
F	860	2'10"		
H	3015	9'11"		
I	3140	10'4"		
M	°		56	
N	°		45	
O	°		56	
P	°		65	
R	mm ft in	120	0'5"	
T	mm ft in	1300	4'3"	
U	mm ft in	1630	5'4"	
V	mm ft in	2935	9'8"	
a <sub>2</sub>	mm ft in	3830	12'7"	
a <sub>3</sub>	mm ft in	2155	7'1"	
a <sub>4</sub>	°		± 38	

## LOADING FORKS SPECIFICATIONS

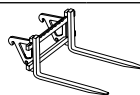

Description	Unit		L20H	
	mm	ft in		
With Loading Fork  Centre of gravity			500	1'8"
Tipping load, full turn (ISO 14397)	kg lb		2170	4,784
Payload according to EN 474-3, 60/80%	kg lb		1300/1700	2,866/3,748
Payload 80%, transport position, 38 ° full turn	kg lb		2,050	4,519

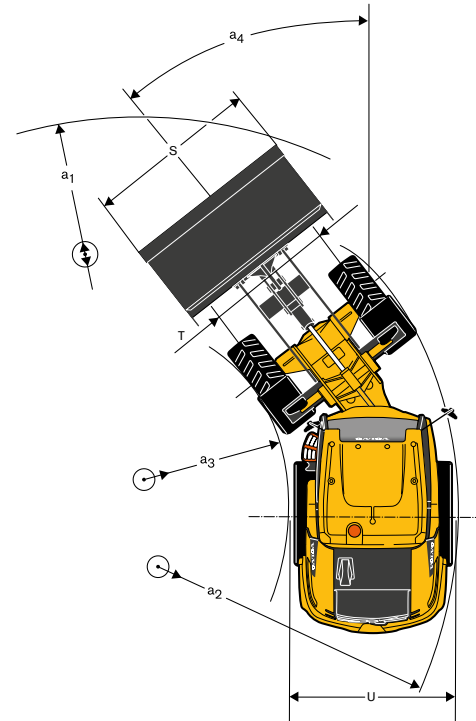
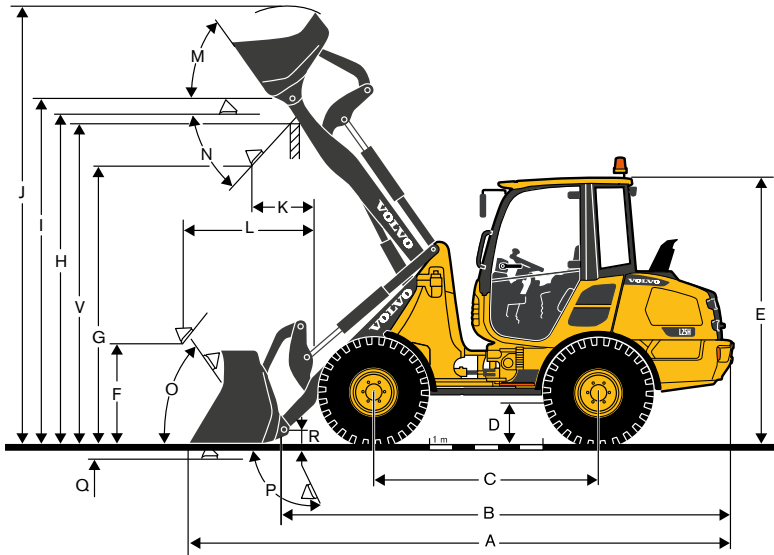

**SPECIFICATIONS ACCORDING TO BUCKET TYPE**

Description	Unit		L25H					
			General Purpose			Light Material		
<b>with SSL attachment bracket &amp; 405/70 R18 tires</b>								
	Capacity heaped	m <sup>3</sup> yd <sup>3</sup>	0.8	1.05	1.0	1.24	1.2	1.6
	Material density	kg/m <sup>3</sup> lb/yd <sup>3</sup>	1900	3,203	1600	2,697	1,400	2,360
Static tipping load, straight (ISO / DIS)	kg	lb	3500	7,716	3,400	7,496	3,700	8,157
Static tipping load, full turn 38° (ISO / DIS)	kg	lb	3100	6,834	3050	6,724	3,300	7,275
Hydraulic lifting capacity, max.	kN	lbf	39	8,768	38	8,543	39.5	8,880
Breakout force	kN	lbf	35	7,868	31	6,969	29	6,519
A Total length	mm	ft in	5190	17'0"	5290	17'4"	5,295	17'4"
J Lift height, max.	mm	ft in	4190	13'9"	4265	14'0"	4,290	14'1"
S Bucket width	mm	ft in	1800	5'11"	1800	5'11"	1,800	5'11"
a <sub>1</sub> Clearance circle	mm	ft in	8400	27'7"	8460	27'9"	8,490	27'10"
Q Digging depth	mm	ft in	85	0'3"	85	0'3"	105	0'4"
G Dump height	mm	ft in	2415	7'11"	2340	7'8"	2,330	7'8"
K Reach at max. height	mm	ft in	785	2'7"	850	2'9"	810	2'8"
L Reach, max.	mm	ft in	1605	5'3"	1670	5'6"	1,610	5'3"
Operating weight	kg	lb	4900	10,803	4950	10,913	4,950	10,913

**DIMENSIONS**

**L25H parallel linkage with 405/70 R18 tires and SSL attachment bracket**

Description	Unit			
B	mm	ft in	4275	14'0"
C	mm	ft in	2050	6'9"
D	mm	ft in	290	0'11"
E	mm	ft in	2485	8'2"
F	mm	ft in	860	2'10"
H	mm	ft in	3015	9'11"
I	mm	ft in	3140	10'4"
M	°			56
N	°			45
O	°			56
P	°			65
R	mm	ft in	120	0'5"
T	mm	ft in	1410	4'8"
U	mm	ft in	1740	5'9"
V	mm	ft in	2935	9'8"
a <sub>2</sub>	mm	ft in	3890	12'9"
a <sub>3</sub>	mm	ft in	2100	6'11"
a <sub>4</sub>	°			± 38

**LOADING FORKS SPECIFICATIONS**

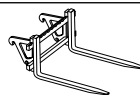

Description	Unit		L25H	
With Loading Fork  Centre of gravity	mm	ft in	500	1'8"
Tipping load, full turn (ISO 14397)	kg	lb	2500	5,512
Payload according to EN 474-3, 60/80%	kg	lb	1500/2000	3,307/4,409
Payload 80%, transport position, 40 ° full turn	kg	lb	2400	5,291

# Equipment

## STANDARD AND OPTIONAL EQUIPMENT

- = Standard
- = Optional

	L20H	L25H
<b>Engine</b>		
Diesel engine, turbo charged, watercooled, with Diesel Oxidation Catalyst (DOC)	•	•
Automatic engine shut down	◦	◦
Hand throttle	•	•
Extra fuel filter with water separator	◦	◦
Fuel pre-heater (12 Volt)	◦	◦
Cold start aid with grid heater (110/220 Volt)	◦	◦
Two stage air filter with primary filter and safty element	•	•
Pre cleaner air filter (Turbo II)	◦	◦
Safety start	•	•
<b>Drivetrain</b>		
Hydrostatic drive	•	•
Combined Brake/Inch pedal	•	•
Operator-selected 100% differential locks in both axles	•	•
Hand control inch valve	◦	◦
Driveline shut off (via parking brake)	◦	◦
Driveline shut off (via parking brake and seat belt)	◦	◦
<b>Electrical system</b>		
Halogen front headlights with high and low beams and integrated parking lights	•	•
Brake and rear lights, turn signals with hazard lights	•	•
Working light (rear right)	•	•
Working lights(2 front/2 rear), Halogen	◦	◦
Working lights (2 front/2 rear), LED	•	•
Power outlet 12Volt/20Ampere (for fuel filling pump)	◦	◦
CareTrack Basic	◦	◦
CareTrack Advanced	◦	◦
<b>Hydraulic system</b>		
Separate gear- pump-section for working and steering hydraulic	•	•
Control valve with three-spool system	•	•
Additional hydraulic pump (high flow)	◦	◦
Single lever with integrated 3rd function	•	•
Flow sharing valve	•	•
Boom suspension system (BSS)	◦	◦
Additional couplings for 3rd hydraulic circuit	◦	◦
Additional 4th hydraulic circuit including couplings	◦	◦
<b>Environmental</b>		
Biodegradable hydraulic oils	◦	◦
<b>Instrumentation &amp; controls</b>		
Single lever control with Working hydraulic functions boom and bucket	•	•
Single lever control with Float function	•	•
Single lever control with Forward/reverse/neutral	•	•
Single lever control with Differential lock	•	•
Single lever control with Speed range low/high	•	•
Single lever control with 3rd hydraulic function	•	•
Single lever control with Horn	•	•
Hazard warning switch	•	•
Analogue indicator for Fuel level	•	•
Analogue indicator for Hydraulic oil temperature	•	•
Illuminated symbols (colour-coded) for Operating hours	•	•
Illuminated symbols (colour-coded) for Direction (forward/reverse)	•	•
Illuminated symbols (colour-coded) for Turn signal (left/right)	•	•
Illuminated symbols (colour-coded) for Grid heater (option)	◦	◦
Illuminated symbols (colour-coded) for Headlights	•	•
Illuminated symbols (colour-coded) for Differential locks	•	•
Illuminated symbols (colour-coded) for Battery charging	•	•
Illuminated symbols (colour-coded) for Travel speed (low/high)	•	•

## STANDARD AND OPTIONAL EQUIPMENT

- = Standard
- = Optional

	L20H	L25H
Illuminated warning symbols with acoustic signal (with ignition on) for coolant temperature, hydraulic oil temperature, hydraulic oil filter, engine oil pressure, air filter restriction, alternator, parking brake	•	•
<b>Safety</b>		
Rotating beacon, Halogen	◦	◦
Rotating beacon, LED	◦	◦
Audible reverse alarm	◦	◦
Audible reverse alarm, switchable	•	•
Audible reverse alarm, smooth sound	◦	◦
Anti-theft system	◦	◦
Safety valves for lifting	◦	◦
Safety valves for tilting	◦	◦
Wheel block	◦	◦
Warning Triangle	◦	◦
Protective guards for Main head lights	◦	◦
Protective guards for Working lights	◦	◦
Protective guards for Rear lights	◦	◦
<b>Cab, Exterior</b>		
ROPS/FOPS-cab isolation mounted	•	•
Lockable door	•	•
All-round tinted tempered glass	•	•
Laminated windscreen	•	•
Cab door latching when open (within machine width)	•	•
Window right hand side openable and lockable at 180° (within machine width)	•	•
Windscreen wiper with washer (front/rear)	•	•
External rear view mirrors (right/left)	•	•
External rear view mirrors (right/left), heated	◦	◦
External rear view mirrors (right/left), enhanced	◦	◦
<b>Cab, Interior</b>		
Cab light	•	•
12 Volt accessories socket	•	•
Mechanic-suspension driver's seat with hand wheel for weight adjustment, integrated 2-point belt system, height and tilt adjustment, horizontal adjustment and backrest adjustment	•	•
Air-suspension and heated driver's seat with automatic weight adjustment, 12 Volt, pneumatic height adjustment, back rest adjustment, horizontal and tilt adjustment, adjustable shock absorber, seat cushion adjustment, pneumatic lumbar support and quick release	◦	◦
Seat belt	•	•
Sunvisor	•	•
Heater with air-filter and defroster (front/rear)	•	•
Cab ventilation	•	•
Storage box	•	•
Air conditioning (AC)	◦	◦
Radio	◦	◦
Preparation for radio	◦	◦

## STANDARD AND OPTIONAL EQUIPMENT

- = Standard
- = Optional

	L20H	L25H
<b>Working Equipment</b>		
Bucket Level Indicator mechanical	◦	◦
Sweeper preparation (switch inside cab, 7 pin electrical socket on boom)	◦	◦
<b>Carriage Body</b>		
Fenders (front/rear)	•	•
Lockable engine hood	•	•
Vertical exhaust pipe	•	•
Towing device	•	•
Lifting eyes	•	•
Tying down eyes	•	•
<b>Service and Maintenance</b>		
Tool kit (tools and grease gun)	•	•
Document box	◦	◦

## STANDARD AND OPTIONAL EQUIPMENT

- = Standard
- = Optional

	L20H	L25H
<b>Other</b>		
ISO-type coupler	◦	◦
Universal Attachment Bracket (SSL)	•	•
Customized machine colour	◦	◦
<b>Official approval</b>		
Quality: DIN/ISO 9001	•	•
Safety: CE - Criteron	•	•
Machine guide-lines 2006/42/EC	•	•
ROPS ISO 3471	•	•
FOPS ISO 3449	•	•
Operating weight: ISO 7131	•	•

## SELECTION OF VOLVO OPTIONAL EQUIPMENT

### High flow hydraulics



### Additional working lights



### Tire options



### Material handling arm



### Boom suspension system



### ISO P-coupler or Skid Steer Load type



Not all products are available in all markets. Under our policy of continuous improvement, we reserve the right to change specifications and design without prior notice. The illustrations do not necessarily show the standard version of the machine.

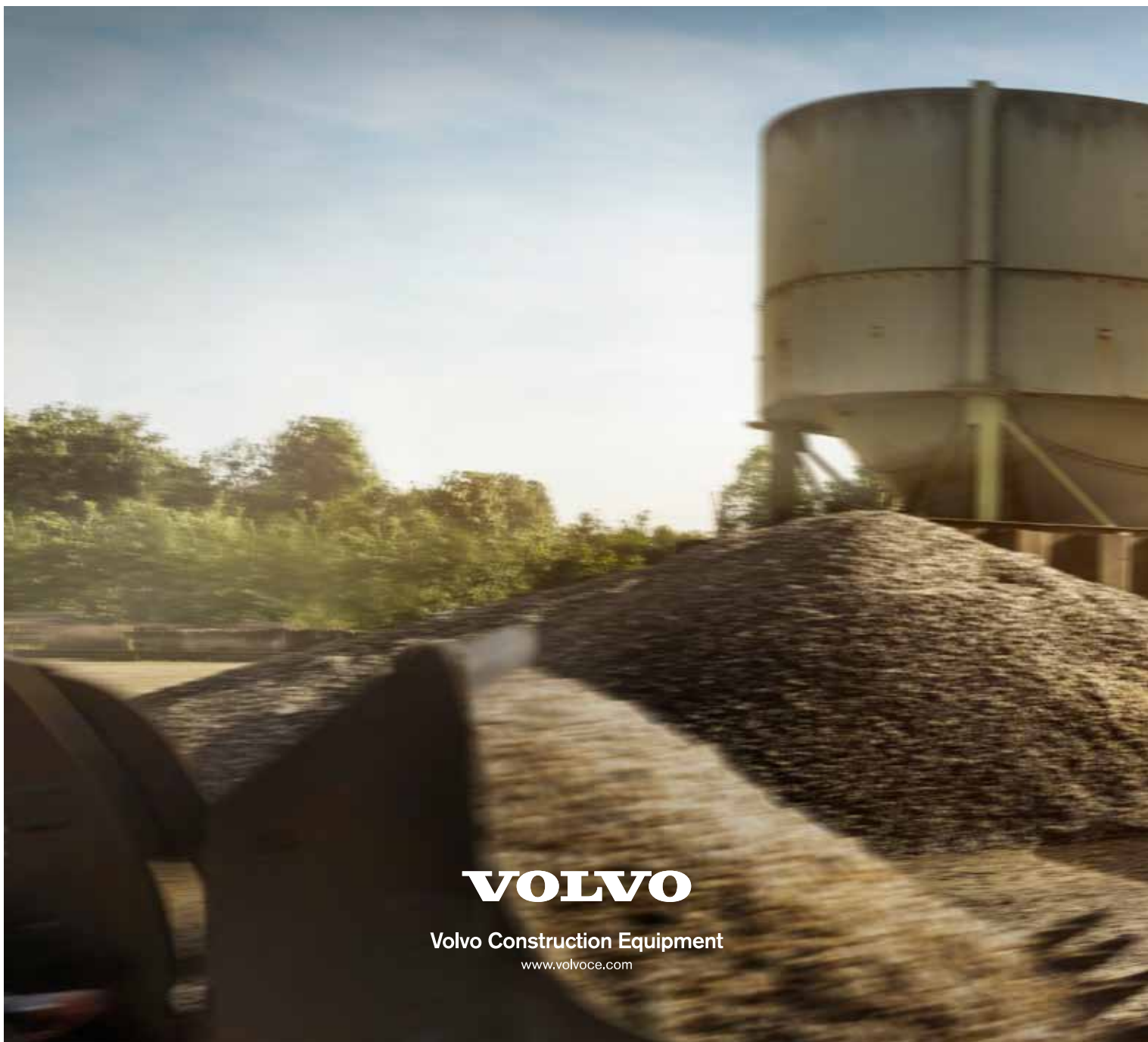

**VOLVO**

Volvo Construction Equipment

[www.volvoce.com](http://www.volvoce.com)