



Volvo Construction Equipment

L45H, L50H

Volvo Wheel Loaders 8.6-9.9 t / 19,114-21,958 lb 98-117 hp



A passion for performance

At Volvo Construction Equipment, we're not just coming along for the ride. Developing products and services that raise productivity – we are confident we can lower costs and increase profits for customers around the globe. Part of the Volvo Group, we are passionate about innovative solutions to help you work smarter – not harder.

Helping you to do more

Doing more with less is a trademark of Volvo Construction Equipment. High productivity has long been married to low energy consumption, ease of use and durability. When it comes to lowering life-cycle costs, Volvo is in a class of its own.

Designed to fit your needs

There is a lot riding on creating solutions that are suited to the particular needs of different industry applications. Innovation often involves high technology – but it doesn't always have to. Some of our best ideas have been simple, based on a clear and deep understanding of our customers' working lives.



You learn a lot in 180 years

Over the years, Volvo has advanced solutions that have revolutionized the use of construction equipment. No other name speaks Safety louder than Volvo. Protecting operators, those around them and minimizing our environmental impact are traditional values that continue to shape our product design philosophy.

We're on your side

We back the Volvo brand with the best people. Volvo is truly a global enterprise, one that is on standby to support customers quickly and efficiently – wherever they are.

We have a passion for performance.

A strong, dedicated, capable dealer network

Our dealers are strategically located throughout North America to provide the equipment you need and the parts and service support you demand for a productive and profitable operation.

The strength of our dealer network is enhanced with extensive individualized product support training at our best-in-class Customer Center in Shippensburg and through hands-on training. Using a great Product Demonstration Center featuring a dedicated area for most common applications, visitors operate equipment from our entire product line under a variety of simulated working conditions. This facility is in year-round use by our dealers and customers.

Building the best starts right here.

The products designed and manufactured by Volvo Construction Equipment have their beginnings at the most advanced Research & Design centers in the industry. Volvo CE machines are designed in 11 R&D centers and produced in 15 manufacturing facilities across the world.

The major R&D center and manufacturing plant in the Americas is located in Shippensburg, Pennsylvania. This facility has been in operation for over 30 years and – with its recently added 200,000 sq. ft. expansion – now covers 570,000 sq. ft. on an 80 acre campus. Dedicated work teams and highly advanced technologies and techniques using the Volvo Production System ensure continuous quality improvements, labor savings and cost control to reach the high quality that our customers have come to expect from Volvo.





Volvo Trucks



Renault Trucks



Mack Trucks



UD Trucks



Volvo Buses



Volvo Construction Equipment



Volvo Penta



Volvo Financial Services

The Best All-rounder

More than 60 years in the making, Volvo is proud to introduce the next generation L45H and L50H wheel loaders. These versatile machines are a powerful asset on every job site in every application.

Intelligent hydraulic system

Volvo's load-sensing hydraulic system drives power to the hydraulic functions according to demand, giving you fast response for shorter cycle times while lowering fuel consumption. Ensuring superior load control together with a careful balance between lifting and tractive forces, this powerful system provides highly effective bucket penetration for all types of digging conditions.



Boom suspension system (BSS)

The optional Boom Suspension System boosts productivity by up to 20% by absorbing shock and reducing the bouncing and bucket spillage that occurs when operating on rough ground. This enables faster and more comfortable work cycles and increases machine life.



Auxiliary hydraulics

Auxiliary hydraulics come standard, optional additional hydraulic circuits are available ex factory covering a wide variety of attachments.



Optional Comfort Drive Control (CDC)

The optional CDC gives the operator the choice to operate the machine by joystick control. This improves operator comfort and ensures better productivity over long working hours. It also reduces operator fatigue, which may occur during repetitive work.





TP LINKAGE



Volvo's unique Torque Parallel (TP) linkage delivers high breakout torque and excellent parallel movement throughout the entire lifting range.



ATTACHMENT RANGE



Volvo's wide range of durable attachments have been purpose-built to work in perfect harmony with Volvo machines. The attachments are designed as an integrated part of the wheel loader for which they're intended – with functions and properties perfectly matched to parameters including link-arm geometry and breakout, rim pull and lifting force.

Get attached

Get flexible on site with original Volvo attachments. Volvo's wide range of durable attachments is designed as an integrated part of the wheel loader for which they're intended. Their functions and properties perfectly match link-arm geometry to optimize breakout, rim pull and lifting force.

Standard Volvo Attachment Bracket (VAB-STD)

Volvo's standard hydraulic attachment bracket VAB-STD, also known as TPV, is internationally ISO standardized and allows a quick and safe interchange of attachments for more flexibility on site. The high visibility, open bracket design enables the operator to clearly see attachment points from the cab.



Tackle every terrain

Whether working on rough terrain or smooth concrete, Volvo's L45H and L50H wheel loaders give you top performance. Quality is built into every inch of the machines, from the differential lock that transfers 100% power to all wheels, to the hydrostatic transmission which offers smooth speed increase. Conquer your site with Volvo.

Inch-brake pedal

The inch-brake pedal gives best possible machine control. Applying light pressure on the pedal "reduces travel speed" further application engages the wet disk brake to stop the loader.



Axles and differential locks

While the heavy-duty planetary axles ensure long life in the toughest conditions, the front and rear 100% differential locks features a dog clutch locking capability, a no slip, no wear design to improve grip and ensure maximum traction on all terrain.



Hydrostatic drive

The fuel efficient hydrostatic transmission matches power to requirement. It provides excellent control in delicate work and full power for more demanding jobs.



Stage IV Engine

Volvo's Stage IV engine complies with the latest emissions legislation and delivers high torque at low engine rpm. The engine features an Exhaust Gas Recirculation (EGR) in combination with an integrated Diesel Particulate Filter (DPF) and Selective Catalytic Reduction (SCR) system. DPF regeneration is maintained without any loss of machine performance or interference with the operation of the machine.



Reversible cooling fan

The hydraulically-driven electronically controlled cooling fan regulates the temperature of vital components. It automatically activates only when it's needed – reducing fuel consumption and noise. The reversible functionality – which blows air in the opposite direction – allows for self-cleaning of the cooling units. Reversible fan can also be operated manually.



OPTIMISED DRIVELINE



The engine, transmission and axles are all designed to work in perfect harmony with the hydraulics and steering for superb performance, durability and reliability.



CAB



The certified ROPS/FOPS cab features ergonomically placed controls, a superior climate control system, all-around visibility and low internal noise levels.

Your control center

Step into Volvo's industry-leading cab; your customized control room. Create your perfect working environment by adjusting the seat and steering wheel to fit your needs, then select the easy-to-reach controls. Excellent all-round visibility gives you the best view of your efficient work.

Fitted to your needs

Operate with single joystick or Volvo style multi lever hydraulic pilot control, depending on your preference. Both provide steady and precise load control.



Human Machine Interface

Increase uptime with Volvo's state-of-the-art Contronic system, which continuously monitors machine performance and communicates diagnostics to the operator via a screen in the cab.



Climate control

Operators remain focused and efficient thanks to Volvo's climate control system. Select optional Automatic Heat Control (AHC) or Air Conditioning (AC) for the perfect cab temperature.



Air filter

The cab air intake is located high on the machine, where air is cleanest. The easy-to-replace pre-filter separates coarser dust and particles before the air passes through the main filter and finally enters the cab, giving the operator the freshest air.



Cab access

Large, anti-slip steps and handrails ensure easy cab entry and exit.



Quiet and steady

Moulded cab roof and walls keep noise and rubber mounts keep vibration to a minimum, reducing operator fatigue.



Small size: big talent

Load-sensing hydraulics

Load-sensing hydraulics deliver power to hydraulic functions only when it's needed, lowering fuel consumption.

OPTIMIZED DRIVELINE



The engine, transmission and axles are all designed to work in perfect harmony with the hydraulics and steering for superb performance and reliability.

Analysis software

Maintain machine uptime by using Volvo's diagnostic computer-based analysis software: MATRIS and VCADS Pro.

TP LINKAGE



Volvo's unique Torque Parallel linkage combines Z-Bar and Parallel linkage in one for high breakout torque and parallel movement through the entire lifting range..

Diesel Exhaust Fluid (DEF)

Volvo offers a total DEF solution that is quality assured, cost efficient and easily accessible. Contact your Volvo dealer for more information.

ATTACHMENT RANGE



Volvo's wide range of high quality attachments are perfectly matched to the machine's linkage, hydraulics and driveline to increase productivity.





BALANCED & COMPACT DESIGN



Volvo's L45H and L50H wheel loaders give you top performance whether working on rough-terrain or smooth concrete.

Steering

Load-sensing hydrostatic steering system supplied from variable displacement pump. Excellent steering performance is maintained even at low engine speed. At the same time fuel consumption is reduced.

CAB



The certified ROPS/FOPS cab features ergonomically placed controls, a superior control system, all-around visibility and low internal noise levels.

SERVICE ACCESS



The service friendly design keeps your routine maintenance quick and efficient with a full access to all main service and maintenance points.

COMPLETE SOLUTIONS



Volvo provides the right solutions throughout the entire life cycle of your machine to lower total cost of ownership.

Differential lock front and rear

Select the differential lock to transfer 100% power to all wheels and reduce tire slippage for maximum traction on soft and slippery ground.

Solid, strong and stable

Volvo's L45H and L50H are compact and well balanced machines whose solid design gives you the strongest performance in the tightest job sites. Quality is built into every inch of the machines.

Stability where you need it

A long wheel base, low center of gravity and good weight distribution gives the machine superior stability on rough and uneven terrain.



Strongest center hinge

The center hinge is designed to withstand considerable horizontal and vertical stress. The upper spherical plain bearing and lower fixed plain bearing are widely spaced to spread forces over a greater area for a long bearing life.



Transversal engine mounting D4J

The Volvo-compliant L45H-L50H engine is assembled transversely – set back from the center of gravity, providing important advantages such as optimal weight distribution on the machine for enhanced driving stability. The powerful and fuel efficient Stage IV engine also provides high torque at low engine speeds for unrivalled performance combined with low fuel consumption. Furthermore, the transversal setup makes all service points and hydraulic pumps easily accessible on one side of the engine.



Counterweight design

The sloped design of the counterweight ensures the machine can achieve very high departure angles, while its compact shape improves manoeuvrability in confined spaces.





BALANCED & COMPACT DESIGN



Volvo's L45H and L50H wheel loaders give you top performance whether working on rough-terrain or smooth concrete. Conquer your site with Volvo.

Adding value to your business

Being a Volvo customer means having a complete set of services at your fingertips. Volvo can offer you a long-term partnership, protect your revenue and provide a full range of customer solutions using high quality parts, delivered by passionate people. Volvo is committed to increasing the positive return on your investment and maximizing uptime.



Complete Solutions

Volvo has the right solution for you. So why not let us provide all your needs throughout the whole life cycle of your machine? By listening to your requirements, we can reduce your total cost of ownership and increase your revenue.



Genuine Volvo Parts

Our attention to detail is what makes us stand out. This proven concept acts as a solid investment in your machine's future. Parts are extensively tested and approved because every part is vital for uptime and performance. Only by using Genuine Volvo Parts, can you be sure that your machine retains the renowned Volvo quality.



Service Network

In order to respond to your needs faster, a Volvo expert is on their way to your job site from one of our Volvo facilities. With our extensive infrastructure of technicians, workshops and dealers, Volvo has a comprehensive network to fully support you using local knowledge and global experience.





CUSTOMER SUPPORT AGREEMENT



The range of Customer Support Agreements offer preventive maintenance, total repairs and a number of uptime services. Volvo uses the latest technology to monitor machine operation and status, giving you advice to increase your profitability. By having a Customer Support Agreement you are in control of your service costs.



SERVICE ACCESS & MAINTENANCE



The service friendly design keeps your routine maintenance quick and efficient with a full access to the engine compartment and engine maintenance points for quick and easy service checks. Service points (radiator, battery, oil, air and hydraulic filters) and quick drains are ground accessible under the engine hood, for quick completion of maintenance checks so you can spend more time working.

Compact your service time

Volvo's L45H and L50H are compact and well balanced machines whose solid design gives you the strongest performance in the tightest job sites. Quality is built into every inch of the machines.

Maintenance-free rear axle oscillation

The oscillating rear axle is supported on maintenance-free cradles. Its bearings and bushings are lubricated-for-life and protected by well proven seals, saving you hours of maintenance time and increasing uptime.



Analysis software

Maximize machine uptime with Volvo's diagnostic analysis software. MATRIS analyses the machine's operational data and VCADS Pro can adjust machine function accordingly.



Engine air filter

The dual element air filter is located in the engine compartment for full protection of the engine.



Grouped grease points

Grease points are grouped together on the loader arm as well as on the centre hinge for easy and quick maintenance.



Volvo L45H, L50H in detail

Engine

Volvo Tier 4f / Stage IV compliant, 4 liter, 4-cylinder in-line turbocharged diesel engine; featuring common rail fuel injection system and externally cooled exhaust gas recirculation (EGR). Exhaust after treatment system includes a diesel oxidation catalyst (DOC), a diesel particulate filter (DPF) and a selective catalytic reduction (SCR). Cooling pack includes side by side arranged radiators for engine coolant, hydraulic oil and charge air cooler.

		L45H		L50H	
Engine		Volvo D4J		Volvo D4J	
Max power at	r/min	1,800 - 2,200		1,800 - 2,200	
	r/s	30 - 36.7		30 - 36.7	
SAE J1995 gross	kW	75	100	87	116.7
	hp	75	100	87	116.7
ISO 9249, SAE J1349 net	kW	73	97.9	85	114
	hp	73	97.9	85	114
Max torque at	r/min	1,450		1,450	
	r/s	24.2		24.2	
SAE J1995 gross	Nm	425	313.5	490	361.4
	ft lbf	425	313.5	490	361.4
ISO 9249, SAE J1349 net	Nm	416	306.8	466	343.7
	ft lbf	416	306.8	466	343.7
Economic working range	r/min	1,200 - 1,800		1,200 - 1,800	
	r/s	20 - 30		20 - 30	
Displacement	l	4	244	4	244
	in ³	4	244	4	244

Drivetrain

Hydrostatic transmission allows for of speed range change without any tractive power interruption. Maximum tractive power is available in all speed ranges, regardless of the driving direction. Automatic power regulation prevents engine stalling in case of additional power demand from the working hydraulics or the auxiliaries, and protects from overheating in case of overload. Fully floating axle shafts with planetary hub reductions and steel casted axle housing. Fixed front axle and oscillating rear axle, both self-lubricated. 100% differential lock on both axles.

		L45H		L50H	
Travel speeds (Forward / Reverse)					
1st speed range	km/h	0-5	0-3.1	0-5	0-3.1
	mi/h	0-5	0-3.1	0-5	0-3.1
2nd speed range	km/h	0-20	0-12.4	0-20	0-12.4
	mi/h	0-20	0-12.4	0-20	0-12.4
Angle of rear axle oscillation	°	±12		±12	
Oscillation at wheel	mm	360	14.2	360	14.2
	in	360	14.2	360	14.2
at Track width	mm	1 730	68.1	1 730	68.1
	in	1 730	68.1	1 730	68.1

Hydraulic system

Closed center load sensing hydraulic system with pilot operated control valves.

System supply:

A variable displacement piston pump provides flow to the working hydraulic and steering system. The steering function has always priority.

A gear pump provides flow to the braking system and the cooling fan.

System control:

Double-acting 3-spools main control valve (4-spools valve as option).

The lift function has four positions: lift, hold (neutral), lower and float position.

An optional automatic boom kick-out can be switched on and off and is adjustable to any position between maximum reach and full lifting height.

The tilt function has three positions: rollback, hold (neutral) and dump.

The standard bucket positioner system allows to easily adjust the tilt angle to a predefined position.

A third and fourth hydraulic functions are available as options to power hydraulic implements (Volvo hydraulic Attachment Bracket, Hi-Tip bucket, angle sweeper etc...)

Filtration:

Full-flow filtration through 10 micron (absolute) filter cartridge in a combined suction-return-filter.

Cooling:

Thermostatically controlled oil flow to oil cooler (fast warm-up, optimized cooling).

		L45H		L50H	
Working pressure max	Mpa	26	3,771	26	3,771
	psi	26	3,771	26	3,771
Flow	l/min	132	34.8	158	41.7
	gal/min	132	34.8	158	41.7
at engine speed	r/min	2,200		2,200	
	r/s	36.7		36.7	
Pilot working pressure	Mpa	2.5	362	2.5	362
	psi	2.5	362	2.5	362

Linkage

Double acting cylinder for all functions

		L45H		L50H	
Linkage system	Torque parallel (TP)	2		2	
	Torque parallel (TP)	1		1	
Lift cylinders		2		2	
Tilt cylinders		1		1	
Lift time (loaded)	s	4.8		4.7	
Lowering time (empty)	s	3.2		3.9	
Dump time	s	1.5		1.2	

Steering System

Load sensing hydrostatic articulated steering with double acting cylinders.

System supply: The steering system has priority feed from the load-sensing axial piston pump with variable displacement.

Steering cylinders: Two double-acting cylinders. Elastical end-stops.

		L45H		L50H	
Steering cylinders		2		2	
Working pressure	Mpa psi	17.5	2,538	17.5	2,538
Maximum flow	l/min gal/min	70	18.5	70	18.5
Max articulation	°	±40		±40	

Brake system

The brake system complies with ISO 3450 requirements. Single circuit service brake featuring hydraulically operated wet disk brakes on rear axle.

An Inching-brake pedal provides hydrostatic wear-less braking in the first stage for precise approach; if applied further the service brakes takes over for final braking and machine immobilization.

Parking brake: Mechanically operated dry disc brake located on the input shaft of the front axle.

Electrical system

Contronic electrical system with central warning light and buzzer, providing clear and easy to read information to the operator. LCD display with main and sub information field, adjustable to various languages.

Display information in three categories:

- Information on continuous operating data,
- Check requests (based on vehicle and error messages)
- Warning (with alarm texts).

Additional audible warning by a buzzer.

Indicator and activation lights for various control and monitoring functions.

Gauges for Diesel Exhaust Fluid level, fuel tank level, speedometer, engine speed, coolant temperature, transmission/hydraulic oil temperature.

A keypad allows easy navigation on the central instrument display.

Direct access buttons for Engine, Transmission, Hydraulics, Axles & Brakes, Electrical system, Vehicle information, Vehicle messages, Service, Settings and Cycle information.

		L45H		L50H	
Voltage	V	24		24	
Batteries	V	2 x 12		2 x 12	
Battery capacity	Ah	2 x 100		2 x 100	
Cold cranking capacity, approx.	A	830		830	
Alternator rating	W/A	3,080/110		3,080/110	
Starter motor output	kW/hp	5.5/7.4		5.5/7.4	

Cab

The cab is tested and approved according to ROPS (ISO 3471, SAE J1040) and FOPS (ISO 3449).

The cab is compliant with ISO 6055 requirements regarding Operator overhead protection - Industrial trucks and SAE J386 regarding Operator Restraint System.

The operator's seat features an adjustable suspension and a retractable seat belt.

Fresh air is filtered through two large elements prior entering, ensuring extremely clean air distribution in the cab.

11 air flow settings or an automatic mode provides efficient ventilation.

Air vents are available to all windows enabling fast de-misting and defrosting.

The contronic monitoring system provides all important information in a central position and all machine controls are located in the operator's field of vision.

Sound Level

		L45H		L50H	
Sound level in cab according to ISO 6396					
LpA	dB(A)	70		70	
LpA (as option)	dB(A)	68		68	
External sound level according to ISO 6395					
LwA	dB(A)	102		102	

Service / Filling capacities





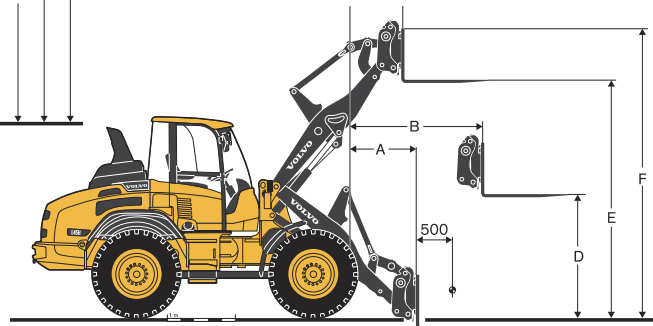
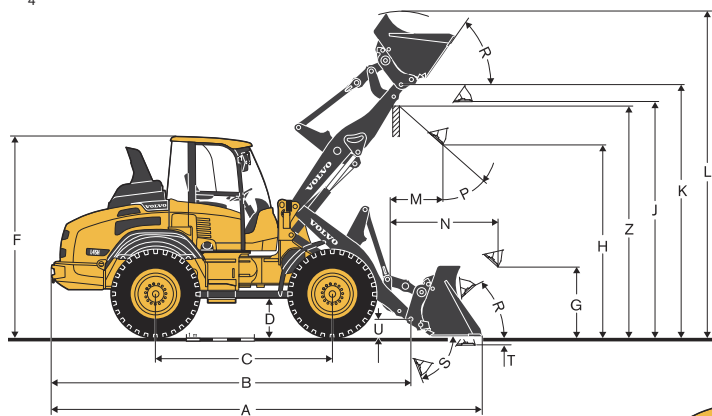
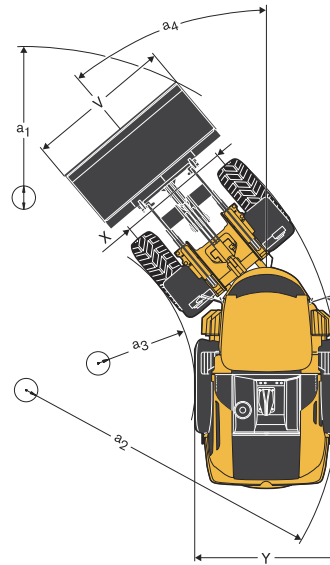

		L45H		L50H	
Fuel tank	l gal	150	39.6	150	39.6
Diesel Exhaust Fluid tank	l gal	20	5.3	20	5.3
Engine oil	l gal	14	3.7	14	3.7
Engine coolant	l gal	20	5.3	20	5.3
Hydraulic tank	l gal	95	25.1	95	25.1
Transmission oil	l gal	1.2	0.3	1.2	0.3
Front axle oil	l gal	17.5	4.6	17.5	4.6
Rear axle oil	l gal	17.5	4.6	17.5	4.6

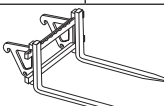
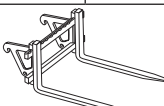
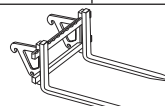
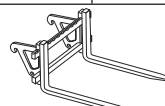





Specifications L45H

			With TP-linkage, TPV attachment bracket and 15.5-25 tires		With TP-linkage, TPZ attachment bracket and 15.5-25 tires	
B	mm	in	5 320	209.4	5 325	209.6
C	mm	in	2 650	104.3	2 650	104.3
D	mm	in	395	15.5	395	15.5
F	mm	in	2 950	116.1	2 950	116.1
G	mm	in	1 000	39.4	1 000	39.4
J	mm	in	3 430	135	3 430	135
K	mm	in	3 685	145	3 685	145
O	°		55		55	
P	°		45		45	
R	°		45		45	
S	°		75		75	
U	mm	in	255	10	255	10
X	mm	in	1 750	68.9	1 750	68.9
Y	mm	in	2 150	84.6	2 150	84.6
Z	mm	in	3 445	135.6	3 360	132.3
a ₂	mm	in	4 745	186.8	4 745	186.8
a ₃	mm	in	2 555	100.6	2 555	100.6
a ₄	°		40		40	



With Loading Fork			TPV attachment bracket		TPV Attachment bracket Long Boom		TPZ attachment bracket		TPZ Attachment bracket Long Boom			
												
Center of gravity 500 mm / 19.7 in												
A	mm	in	785	30.9	1 135	44.7	650	25.6	1 020	40.1		
B	mm	in	1 475	58	1 745	68.7	1 375	54.1	1 645	64.7		
C	mm	in	650	25.6	825	32.5	550	21.6	725	28.5		
D	mm	in	1 705	67.1	1 705	67.1	1 740	68.5	1 740	68.5		
E	mm	in	3 490	137.4	3 695	145.5	3 530	139	3 735	147		
F	mm	in	4 225	166.3	4 430	174.4	4 265	167.9	4 470	176		
Tipping load full turn (ISO 14397)			kg	lb	4 420	9,744	3 920	8,642	4 670	10,295	4 170	9,193
Working load acc. to EN 474-3, 60/80%			kg	lb	2 650 / 3 530	5,842 / 7,782	2 350 / 3 130	5,180 / 6,900	2 800 / 3 730	6,173 / 8,223	2 500 / 3 330	5,511 / 7,341
Working load 80%, transport position, 40 deg. and full turn			kg	lb	4 000	8,818	-	-	4 000	8,818	-	-

With TP-Linkage, TPV attachment bracket and 15.5-25 tires			GENERAL PURPOSE				LIGHT MATERIAL				4-in-1		High-Tip		LONG BOOM	
																
Capacity heaped	m ³	yd ³	1.4	1.8	1.5	2.0	1.8	2.4	2.0	2.6	1.2	1.6	2	2.6	-	-
Material density	kg/m ³	lb/yd ³	1 800	3,034	1 700	2,865	1 400	2,360	1 200	2,022	1 900	3,202	1 000	1,685	-300	-505
Static tipping load, straight (ISO 14397)	kg	lb	5 940	13,095	5 860	12,919	5 710	12,588	5 600	12,345	5 580	12,301	4 880	10,758	-	-
Static tipping load, full turn 40° (ISO 14397)	kg	lb	5 250	11,574	5 190	11,442	5 050	11,133	4 960	10,935	4 940	10,890	4 320	9,524	-640	-1,410
Hydraulic lifting capacity, max.	kN	lbf	70	15,736	69.4	15,601	67.5	15,174	66	14,837	66.5	14,950	57.5	12,927	-	-
Breakout force	kN	lbf	71	15,961	69.4	15,601	61.6	13,848	55.8	12,544	76.7	17,242	-	-	-	-
A Total length	mm	in	6 370	250.8	6 385	251.3	6 505	256.1	6 615	260.4	6 295	247.8	6 955	273.8	-	-
L Lift height, max.	mm	in	4 740	186.6	4 790	188.5	4 810	189.3	4 940	194.5	4 815	189.5	5 695	224.2	200	8
V Bucket width	mm	in	2 250	88.6	2 250	88.6	2 250	88.6	2 250	88.6	2 250	88.6	2 250	88.6	-	-
a Clearance circle	mm	in	10 310	405.9	10 320	406.3	10 390	409	10 460	411.8	10 305	405.7	10 675	420.2	-	-
T Digging depth	mm	in	85	3.3	85	3.3	85	3.3	85	3.3	120	4.7	95	3.7	-	-
H Dump height, 45°	mm	in	2 800	110.2	2 780	109.4	2 690	105.9	2 610	102.7	2 790	109.8	4 230	166.5	200	8
M Reach at max. height	mm	in	940	37	960	37.8	1 040	40.9	1 115	43.9	830	32.6	1 500	59	170	7
N Reach, max.	mm	in	1 770	69.6	1 785	70.2	1 860	73.2	1 935	76.1	1 650	64.9	2 685	105.7	270	10.6
Operating weight	kg	lb	8 770	19,334	8 790	19,378	8 800	19,400	8 830	19,466	8 990	19,819	9 230	20,348	-	-





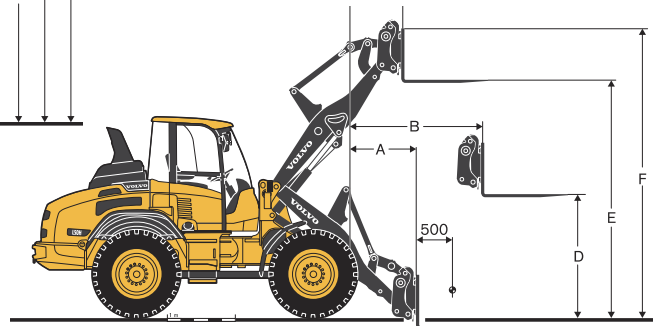
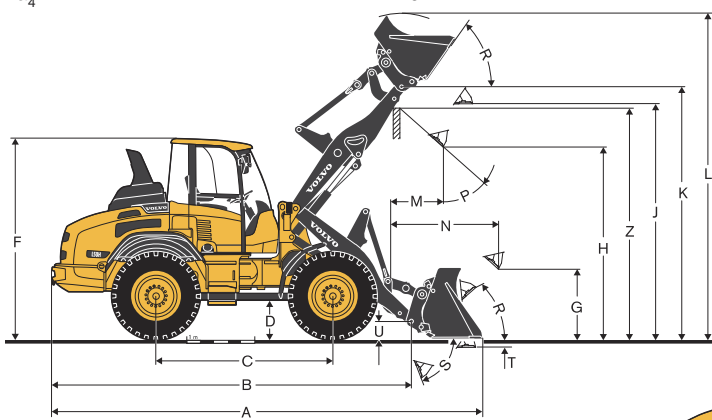
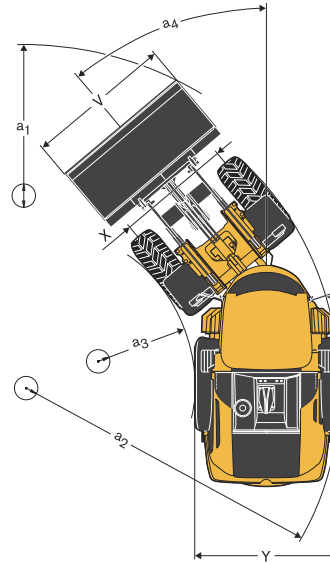

With TP-Linkage, TPZ attachment bracket and 15.5-25 tires			GENERAL PURPOSE				LIGHT MATERIAL				4-in-1		High-Tip		LONG BOOM	
																
Capacity heaped	m ³	yd ³	1.4	1.8	1.6	2.1	1.8	2.4	2.0	2.6	1.3	1.7	2	2.6	-	-
Material density	kg/m ³	lb/yd ³	1 900	3,202	1 600	2,696	1 400	2,360	1 300	2,191	1 900	3,202	1 100	1,854	-300	-505
Static tipping load, straight (ISO 14397)	kg	lb	6 220	13,712	6 120	13,492	6 020	13,271	5 890	12,985	6 050	13,338	5 260	11,596	-	-
Static tipping load, full turn 40° (ISO 14397)	kg	lb	5 500	12,125	5 420	11,949	5 330	11,750	5 210	11,486	5 350	11,794	4 650	10,251	-640	-1,410
Hydraulic lifting capacity, max.	kN	lbf	74	16,636	72.5	16,298	71.3	16,029	69.5	15,624	72	16,186	62	13,938	-	-
Breakout force	kN	lbf	66	14,837	60.5	13,601	55.5	12,477	50	11,240	65	14,612	-	-	-	-
A Total length	mm	in	6 260	246.5	6 335	249.4	6 415	252.5	6 525	256.9	6 270	246.8	6 825	268.7	-	-
L Lift height, max.	mm	in	4 680	184.2	4 750	187	4 820	189.7	4 890	192.5	4 730	186.2	5 610	220.8	200	8
V Bucket width	mm	in	2 250	88.5	2 250	88.5	2 250	88.5	2 250	88.5	2 250	88.5	2 250	88.5	-	-
a Clearance circle	mm	in	10 125	398.6	10 165	400.1	10 210	402	10 275	404.5	10 165	400.2	10 590	416.9	-	-
T Digging depth	mm	in	90	3.5	90	3.5	90	3.5	90	3.5	45	1.8	80	3.1	-	-
H Dump height, 45°	mm	in	2 875	113.1	2 815	110.8	2 755	108.4	2 675	105.3	2 865	112.8	4 140	163	200	8
M Reach at max. height	mm	in	860	33.8	900	35.4	955	37.6	1 030	40.5	850	33.4	1 370	53.9	170	7
N Reach, max.	mm	in	1 685	66.3	1 725	67.9	1 780	70	1 855	73	1 670	65.7	2 540	100	240	9.4
Operating weight	kg	lb	8 670	19,114	8 710	19,202	8 700	19,180	8 730	19,246	8 920	19,665	9 120	20,106	-	-

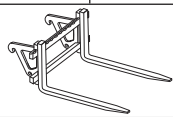
Specifications L50H

		With TP-linkage, TPV attachment bracket and 15.5-25 tires	
B	mm in	5 380	211.8
C	mm in	2 650	104.3
D	mm in	435	17.1
F	mm in	2 980	117.3
G	mm in	1 000	39.4
J	mm in	3 525	138.8
K	mm in	3 780	148.8
O	°	54	
P	°	45	
R	°	44	
S	°	76	
U	mm in	255	10
X	mm in	1 730	68.1
Y	mm in	2 190	86.2
Z	mm in	3 535	139.2
a ₂	mm in	4 760	187.4
a ₃	mm in	2 540	100
a ₄	°	40	



With Loading Fork	TPV attachment bracket		TPV Attachment bracket Long Boom		
	Center of gravity 500 mm / 19.7 in				
A	mm in	800	31.5	1 060	41.7
B	mm in	1 505	59.2	1 705	67.1
C	mm in	655	25.8	785	30.9
D	mm in	1 745	68.7	1 745	68.7
E	mm in	3 585	141.1	3 735	147
F	mm in	4 320	170.0	4 470	176
Tipping load full turn (ISO 14397)	kg lb	4 810	10,604	4 410	9,722
Working load acc. to EN 474-3, 60/80%	kg lb	2 880 / 3 840	6,349 / 8,465	2 640 / 3 520	5,820 / 7,760
Working load 80%, transport position, 40 deg. and full turn	kg lb	4 000	8,818	-	-

With TP-Linkage, TPV attachment bracket and 15.5-25 tires			GENERAL PURPOSE				LIGHT MATERIAL				4-in-1		High-Tip		LONG BOOM	
																
Capacity heaped	m ³	yd ³	1.5	2	1.6	2.1	1.8	2.4	2.0	2.6	1.4	1.8	2.3	3	-	-
Material density	kg/m ³	lb/yd ³	1 900	3,202	1 700	2,865	1 500	2,528	1 300	2,191	1 900	3,202	1 000	1,685	-250	-421
Static tipping load, straight (ISO 14397)	kg	lb	6 560	14,462	6 510	14,352	6 400	14,109	6 290	13,867	6 080	13,404	5 550	12,235	-	-
Static tipping load, full turn 40° (ISO 14397)	kg	lb	5 810	12,808	5 750	12,676	5 670	12,500	5 570	12,279	5 390	11,882	4 910	10,824	-510	-1,124
Hydraulic lifting capacity, max.	kN	lbf	86.5	19,446	86	19,333	84.5	18,996	83	18,659	81.5	18,322	73	16,411	-	-
Breakout force	kN	lbf	72	16,186	69	15,511	64	14,387	58	13,039	65	14,612	-	-	-	-
A Total length	mm	in	6 460	254.3	6 495	255.7	6 580	259	6 690	263.4	6 560	258.2	7 030	276.8	-	-
L Lift height, max.	mm	in	4 880	192.1	4 900	192.9	4 980	196	5 235	206.1	4 905	193.1	5 915	232.9	150	5.9
V Bucket width	mm	in	2 250	88.6	2 250	88.6	2 250	88.6	2 250	88.6	2 250	88.6	2 250	88.6	-	-
a ₁ Clearance circle	mm	in	10 360	407.9	10 385	408.8	10 435	410.8	10 505	413.6	10 475	412.4	10 740	422.8	-	-
T Digging depth	mm	in	95	3.7	95	3.7	95	3.7	95	3.7	130	5.1	105	4.1	-	-
H Dump height, 45°	mm	in	2 865	112.8	2 845	112	2 775	109.2	2 695	106.1	2 745	108	4 330	170.4	-	-
M Reach at max. height	mm	in	965	38	1 000	39	1 040	40.9	1 115	43.9	965	38	1 505	59.2	130	5.1
N Reach, max.	mm	in	1 810	71.2	1 830	72	1 890	74.4	1 970	77.5	1 810	71.2	2 710	106.7	200	8.0
Operating weight	kg	lb	9 480	20,900	9500	20,944	9 490	20,921	9 520	20,988	9 740	21,473	9 960	21,958	-	-

Equipment

STANDARD EQUIPMENT

	L45H	L50H
Service		
Standard tool kit	•	•
Drain valves for engine oil, hydraulic oil and coolant	•	•
Hydraulic pressure test ports with quick-connects	•	•
Engine		
Dry-type air filter	•	•
Three stage air cleaner, pre-cleaner, primary and secondary filter	•	•
Preparation for pre-cleaner	•	•
Preheating of induction air	•	•
Side by side (single layer) cooling pack	•	•
Coolant level monitoring	•	•
Filtration screens on air inlets	•	•
Fuel pre-filter with water trap	•	•
Crank case breather oil trap	•	•
Exhaust after-treatment system	•	•
Exhaust heat ventilation	•	•
Electrical system		
24 V electrical system (2 X 12V maintenance free batteries)	•	•
Batteries covered by lockable engine hood	•	•
Electronic battery cut-off switch	•	•
Alternator 110 A / 3,080 W	•	•
Electric horn	•	•
Lighting		
Main head lights (halogen) upper/dipped/asymmetrical	•	•
Working lights, halogen (2 front/2 rear)	•	•
Parking lights	•	•
Rear lights	•	•
Brake lights	•	•
Direction indicators	•	•
Hazard warning lights	•	•
Reversing lights	•	•
Cab lighting	•	•
Instrumentation & controls		
24 Volt accessories socket	•	•
Hazard warning switch	•	•
Safety start	•	•
Electronic Information System		
Contronic display with keypad	•	•
Monitoring of fuel level, fuel consumption, Diesel Exhaust Fluid level, temperatures and pressures (engine, ambient, transmission, hydraulics, brakes and steering)	•	•
LED-illuminated symbols are available for direction indicators, transportation & work lights, rotating beacon, parking brake, engine oil pressure, battery charging, differential lock, boom suspension system, DEF warning, regeneration and high exhaust temperature	•	•
Drivetrain		
Hydrostatic drive	•	•
Inching-brake pedal (hydrostatic wearless braking ahead of service brake application)	•	•
Wet disc service brakes, hydraulically operated	•	•
Dry disc parking brake	•	•
Operator-selected 100% differential locks in both axles	•	•
Hydraulic system		
Load-Sensing Hydraulics	•	•
Flow sharing main control valve, three-spool system	•	•
Variable displacement axial piston pump for working hydraulic and steering	•	•
Gear pump for brake system and cooling fan	•	•
3rd hydraulic circuit	•	•
Bucket positioner	•	•
Indicator glass for hydraulic oil level	•	•
Thermostatically controlled oil flow to oil cooler (fast warm-up, optimized cooling)	•	•
Cab, Exterior		
ROPS/FOPS-cab	•	•
Cab cushioning	•	•
Single key kit door / start	•	•
Lockable door	•	•
Door stops	•	•
All-round tinted safety glass	•	•
Sliding window RHS	•	•
Two-stage air inlet filtration with large easy to replace elements	•	•
External rear view mirrors (right/left)	•	•
Windscreen wiper (front/rear)	•	•
Windscreen washer (front/rear)	•	•

	L45H	L50H
Cab, Interior		
Acoustic inner lining	•	•
Floor mat	•	•
Adjustable steering column	•	•
Left and right armrests	•	•
4-way adjustable operator's seat	•	•
Retractable seat belt	•	•
Sun visor	•	•
Interior rear view mirrors	•	•
Air conditioner	•	•
Automatic heat control	•	•
Several air vents on the front and rear of the cab, allowing excellent climate control, de-misting and defrosting	•	•
Interior light	•	•
Coat hook	•	•
Cup holder	•	•
Storage box in the cab	•	•
24 V power outlet	•	•
Emergency hammer	•	•
Working Equipment		
Automatic bucket positioner	•	•
Hydraulic quick-change attachment bracket	•	•
External equipment		
Fenders (front/rear)	•	•
Lockable engine hood	•	•
Lockable fuel-tank cap	•	•
Lockable Diesel Exhaust Fluid filler cap	•	•
Vertical exhaust	•	•
Frame, joint lock	•	•
Towing device	•	•
Lifting eyes and Tie-down points	•	•
Official approval		
Machine conforming to European directive 2006/42/EC	•	•
Electromagnetic compatibility (EMC) conforming to European directive 2014/30/EC	•	•
Noise emissions in the environment conforming to directive 2000/14/EC	•	•
Tipping load and payload conforming to ISO 14397-1	•	•
ROPS conforming to ISO 3471	•	•
FOPS conforming to ISO 3449	•	•

OPTIONAL EQUIPMENT

	L45H	L50H
Service		
Wheel chock	•	•
Tool Kit	•	•
Central Lub unit (Volvo)	•	•
Engine		
Hand throttle	•	•
Automatic engine shutdown	•	•
Turbo II Prefilter	•	•
Air pre-cleaner, oil-bath type	•	•
Fan speed, high ambient	•	•
Reversible cooling fan	•	•
Engine Block heater, 120 V	•	•
Fuel pre-heater	•	•
Electrics		
Rotating beacon foldable	•	•
Preparation for magnetic rotating beacon	•	•
Magnetic rotating beacon	•	•
Reverse alarm audible	•	•
Reverse alarm audible & switchable	•	•
Reverse alarm audio visual switchable	•	•
Rear view camera including monitor (color)	•	•
LED Working lights on cab, 2 front / 2 rear	•	•
LED Working lights on cab, 4 front / 4 rear	•	•
Additional LED Working lights, 2 front / 1 rear	•	•
Elevated headlights 350 mm / 13.8 in	•	•
Road light equipment width 2.5 m / 8.2 ft	•	•
Power outlet 12 V	•	•
Anti theft device	•	•
Care Track GSM	•	•
Care Track Satellite	•	•

OPTIONAL EQUIPMENT

	L45H	L50H
Cab		
Door all glass	•	•
Door with sliding window	•	•
Foldable right hand window	•	•
Split door (Door with foldable window)	•	•
Heated rearview mirrors	•	•
Seat fab. air/susp. heat	•	•
Seat mec./susp.	•	•
Seat belt 3"	•	•
Seat belt warning	•	•
Comfort drive control (CDC)	•	•
Radio preparation 12 V	•	•
Radio	•	•
Joystick control including F/R/N, up/down-shift, differential lock and 3rd hydraulic function	•	•
Multi-lever control, including F/R/N, up/down-shift, differential lock, horn and 3rd hydraulic function	•	•
Multi-lever control, including F/R/N, up/down-shift, differential lock, horn, 3rd & 4th hydraulic function	•	•
Timer cab heating (Pause heating)	•	•
Auxiliary cab & engine heater	•	•
Drivetrain		
Hand-inching	•	•
Hydraulics		
Hyd. oil mineral VG46 HV	•	•
Hyd. oil mineral VG32 HV	•	•
Hyd. oil mineral VG68 HV	•	•
Boom suspension system	•	•
Boom kick-out	•	•
Safety valve for lift cylinder	•	•
Tilt control	•	•
Tilt speed limiter mechanical	•	•
Safety valve for tilt cylinder	•	•
4th function	•	•
Hydraulic Couplings	•	•
High flow (125 l/min / 33 gal/min)	•	•
High flow (140 l/min / 37 gal/min)	•	•
Auxiliary hydraulic's return line (via filter)	•	•

	L45H	L50H
Other		
Long boom	•	•
Preparation for licence plate	•	•
Side marking reflectors	•	•
SMV warning triangle	•	•
Trailer socket	•	•
Color Level 1 (yellow parts)	•	•
Color Level 1+2	•	•
Wheel/Tires		
440/80R24	•	•
500/70R24	•	•
540/65R24	•	•
15.5R25	•	•
17.5R25	•	•
550/65R25	•	•
600/55-26.5	•	•
Protective equipment		
Front Mud flaps	•	•
Extended mud flaps	•	•
Mudguard extension 75 mm / 2.95 in	•	•
Belly guards, front/rear	•	•
Rear lights protection	•	•
Headlights protection	•	•
Working lights guards, front/rear	•	•
Windshield guard, rear	•	•
Windshield guard, front	•	•
Engine hood protection	•	•

ATTACHMENTS L45H, L50H

Buckets

Straight with teeth and bolt on edges
High tipping
Light material
Clamp

Other attachments

Log grapples
Forks
Material handling arm

SELECTION OF VOLVO OPTIONAL EQUIPMENT

Boom suspension system



Comfort Drive Control



Reversible cooling fan



3rd & 4th hydraulic function



Auxiliary cab & engine heater



Central lubrication system



Not all products are available in all markets. Under our policy of continuous improvement, we reserve the right to change specifications and design without prior notice. The illustrations do not necessarily show the standard version of the machine.

VOLVO

Volvo Construction Equipment

www.volvoce.com